

advice series



energy efficiency

IN TRADITIONAL BUILDINGS

energy efficiency

IN TRADITIONAL BUILDINGS



Comhshaol, Oidhreacht agus Rialtas Áitiúil
Environment, Heritage and Local Government



Contents

INTRODUCTION	4
1. CONSERVATION AND SUSTAINABILITY	5
What is a 'traditional' building?	5
Embodied energy and whole-life costing	7
2. UNDERSTANDING THE BUILDING	10
The effects of climate	10
Planning for warmth	13
Building use	15
Heat loss from buildings	16
Heat transfer through building materials	16
Thermal bridging	18
Ventilation and indoor air quality	18
Thermal mass	20
Assessment methods	22
Building Energy Rating (BER) and traditional buildings	23
3. UPGRADING THE BUILDING	26
Building management	26
Building condition	26
Preliminaries to upgrading	27
Products and materials	27
Reducing draughts	29
Roofs	29
Walls	35
Windows, doors and rooflights	39
Floors	46
Services	48
4. CASE STUDIES	54
A Regency house in the city	54
A detached country house	56
A pair of rural cottages	58
A converted stable yard	59
A mixed-use building in a town	60
Living over the shop	62
A converted Georgian townhouse	64
Places of worship	65
GLOSSARY	72

Introduction

It is Government policy to reduce energy use and carbon dioxide emissions from the burning of fossil fuels. The European Directive on the Energy Performance of Buildings (2002/91/EC) adopted into Irish law in 2006, specifically targeted energy requirements of buildings whether new or existing, residential or non-residential. In order to meet the requirements of the directive (which was recast in 2010), and to address the fact that buildings contribute significantly to this country's energy consumption, the standard of energy conservation required of new buildings has risen significantly in recent years. Energy performance standards will continue to rise so that, by 2016, it is intended that new houses will be mainly passive, that is to say, designed to consume little or no energy in use. However, upgrading the thermal efficiency of the existing building stock presents a challenge, particularly where the building was built using traditional materials and construction methods and is of architectural or historical interest.

People enjoy old buildings for the sense of history they evoke, the craftsmanship they represent and for the solidity of their construction. However, there is sometimes a perception that old buildings are cold. It is true that they can sometimes be draughty, and the degree of tolerance shown by their users is testimony to the value people place on architectural character and a sense of place, which compensate to quite a large extent for any shortcomings in comfort. Historically, heating solutions included a roaring fire or an ever-burning stove emitting pleasurable warmth. Of course, our forebears were somewhat hardier than ourselves, having different expectations in terms of heat and comfort. Extra clothing and bedclothes, hot-water bottles and even different dietary habits played their part in keeping people warm in their day-to-day lives during the colder months. From the mid-twentieth century onwards, the availability of cheap fossil fuels enabled an increasing number of households to avail of central heating, supplying heat to all rooms; a concept almost unheard of in earlier times.

Today, however, there is an increasing awareness of the importance of energy and fuel conservation. In tandem with higher expectations in relation to the general warmth of the indoor environment, this awareness has led to new standards and types of building construction intended to ensure that the

energy consumed by a building during its useful life is minimised. These new standards in modern buildings have influenced the expectations of users of older buildings. When dealing with a historic building, there are other matters which the users and building professionals who care for old buildings should address, matters that are to do with the architectural character of a building, repair and maintenance issues, older forms of construction and the particular characteristics of traditional building materials.



A typical brick-fronted, nineteenth-century house with solid masonry walls, single-glazed sash windows and slate roof

This booklet sets out to provide introductory guidance for owners and to act as an aide-memoire for building professionals and contractors. While the main objective is to address how the thermal efficiency of traditionally built buildings can be enhanced, it is intended to balance this with the conservation of the architectural heritage. To that end, this booklet explores ways of improving energy efficiency while maintaining architectural character and significance, the intention is to show how to improve the quality of the architectural environment while maintaining the historic fabric of traditional buildings.

1. Conservation and Sustainability

Arising from the way they are designed and constructed, traditional buildings respond to changes in temperature in very particular ways. Properly understood, the way traditional buildings behave can be exploited to make them more comfortable and more energy-efficient, while saving money on heating bills. Good architectural conservation is environmentally sustainable; as a nation we should be conserving historic buildings not only for their cultural value but also because it makes environmental sense. It is important to have realistic expectations of older buildings, and to find the right use for them. Indeed, when we appreciate that the designers of these historic buildings were often concerned with saving energy, fuel costs historically being even higher than they are now, we understand that older buildings have important lessons to teach, with regard both to the design of new buildings and the repair of existing ones. In the absence of an understanding of how traditional buildings and materials behave, modern technologies may be misapplied and can have detrimental impacts on historic building fabric.

What is a 'traditional' building?

Traditional buildings include those built with solid masonry walls of brick and/or stone, often with a render finish, with single-glazed timber or metal windows and a timber-framed roof; usually clad with slate but often with tiles, copper or lead. These were the dominant forms of building construction from medieval times until the second quarter of the twentieth century. Less commonly, traditional buildings had corrugated iron roofs or cladding while many vernacular buildings were constructed with stone and/or mud walls and thatched roofs.

The twentieth century saw the development and widespread use of twin-leafed masonry construction, commonly called a cavity wall, which is based on a fundamentally different approach to keeping the interior of a building dry. The cavity wall consists of an outer leaf which is presumed always to be wet, and an inner leaf which it is intended should always be dry, the two leaves of the wall being separated by an air-filled cavity. In the earliest cavity wall constructions, the cavity was left empty but latterly was often partially or totally filled with an insulating material.



A typical traditional farmhouse, built of stone and finished in lime render, with a slate roof and timber windows

Traditional masonry walls of stone or brick do not contain a cavity. In stone construction, the core or central portion of the wall was often filled with small stones and lime mortar. While brickwork was often left exposed externally and plastered internally, rubble walls were generally rendered externally in a breathable lime plaster. Solid masonry walls relied on their thickness to cope with atmospheric moisture, being sufficiently thick to ensure that drying out took place before moisture from rainwater passed through the wall to cause damp on the inner face. The breathable lime plaster allowed the moisture in the walls to dry out to the external air. Virtually all buildings constructed in this country before 1940 were built of this type of masonry construction. The use of lime extended to other components of the building; older buildings are often found to have lime pugging between the joists in the floor, providing additional thermal and acoustic insulation.

Many traditionally built buildings are protected structures under the Planning and Development Acts, and therefore are identified as being of special interest. However, there are many other traditionally built buildings that do not have statutory protection but may nonetheless be worthy of care in their repair and enhancement for contemporary living.

Dwelling Type	2006 Number	2006 % of Total
Detached house	625,988	42.8
Semi-detached house	398,360	27.2
Terraced house	257,522	17.6
Flat/Apartment	139,872	9.6
Bed-sit	8,751	0.6
Not stated	31,803	2.2
Total	1,462,296	100

Irish dwelling types: This chart indicates that detached buildings represent almost half of all dwellings, which has implications for energy consumption

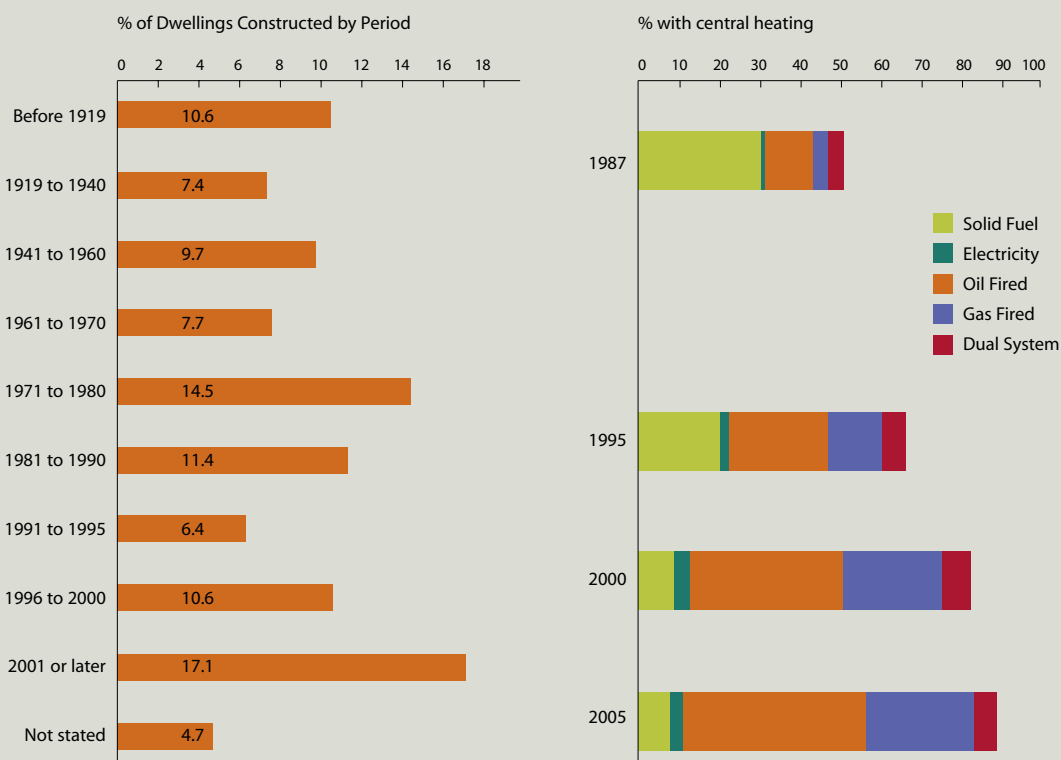

Age of the Irish housing stock: According to 2006 figures, approximately 18% of the housing stock dates from before 1940

Types and percentage of central heating in Irish homes: There has been a trend towards central heating and with it higher expectations of thermal comfort

(Source: Energy in the Residential Sector, Sustainable Energy Ireland, 2008. Information adapted from Central Statistics Office 2006)

Embodied energy and whole-life costing

It has been said that the greenest building is the one that is already built. It is important to recognise that the reuse or continued use of older buildings is a key component of sustainable development and energy-conservation practice. Common sense would suggest making use of existing buildings before building anew as demolition waste accounts for a large percentage of landfill, which is an environmental burden, while the production and/or importation of new building materials accounts for a significant amount of energy use. In addition, the linked concepts of embodied energy and whole-life costing should be taken into account in reaching a decision as to what is most energy efficient.

'Embodied energy' is the term used to describe the energy that was required to extract, process, manufacture, transport and install building materials and is now deemed to be embodied in the finished building. Materials which have been subjected to little processing or were processed using relatively small amounts of energy, for example lime mortars (as opposed to cement mortars), local timber and native thatch, are therefore low in embodied energy. Materials such as steel, concrete and modern bricks, which require a great deal of energy to manufacture, are higher in embodied energy. Similarly, building materials transported long distances have higher embodied energy, as their transport generally requires the use of non-renewable fuels. Entirely replacing an existing building with a new one involves a significant outlay of embodied energy both in the act of demolition (which includes the waste of existing materials, some of which are capable of repeated reuse) and in the use of new materials which have consumed energy in their production and transportation.

'Whole-life costing' involves considering not just the initial capital cost that goes into constructing a building (including all ancillary design and other costs), but also the cost of renovation, maintenance and day-to-day operation over the period of its useful life. Certain materials have a relatively short lifespan, yet considerable energy has been used in their manufacture, while components made of artificial material are often difficult to repair. For example, the techniques of repair are well understood for timber windows and the necessary skills are readily available

whereas uPVC is not easily repaired, potentially leading to a shorter life for the window unit. Natural slate requires energy in its extraction and there are impacts on the environment caused by quarrying. However, these are offset by the fact that, because it is a natural product that is not manufactured, natural slate is low in embodied energy compared with artificial roofing products. In addition, the lifespan of a natural slate is two to three times that of fibre-cement, concrete or clay tile, and natural slate has the potential for reuse. This means that over its lifespan, a natural slate roof may have a lesser environmental impact.

The link between embodied energy and whole-life costs is important and worth considering. Analysis of lifecycle costs is complicated, as the cost of production of materials and the energy used to manufacture them varies continuously. Identification of the energy embodied in building materials and/or consumed in operating a building from year to year by heating and lighting is a simpler matter and so it is possible to measure and quantify the impact of construction actions.

The embodied energy in buildings that are poorly managed and insulated can be the equivalent of many years of the energy required to heat and light the same building. As energy efficiency standards improve, less energy is required to heat and light a building and so the embodied energy of materials used in new construction becomes more significant as it represents a greater proportion of the overall energy consumed or incorporated by a building. This is an important phenomenon, having been identified only recently, and is something that will change the nature of debate and decision-making concerning the reuse of buildings and energy performance in the years to come.

A study commissioned by Dublin City Council entitled *Built to Last: The Sustainable Reuse of Buildings* (2004) looked at the lifecycle cost of five buildings and compared the monetary and environmental cost of refurbishment versus demolition and reconstruction. The study found that the construction of new buildings on brown-field sites was almost always more expensive than retaining and reusing the existing buildings. The only exception was where the extent of building repair and refurbishment required was very high. The refurbished existing building was also found to perform better in environmental terms, minimising the depletion of non-renewable resources being therefore more sustainable.

The subject of embodied energy is significant and needs further research. Many factors come into play in this topic; for example, the performance of traditional buildings that, for whatever reason, cannot be insulated; the remaining lifespan of a building; its architectural heritage significance; the scale of repair works to be undertaken, and so on. Carbon-emission evaluations are more measurable than monetary costs, energy-related returns on investment over a sixty- or a hundred-year period being very hard to predict.

However, there is one clear rule of thumb: the greatest cost-benefits generally arise from the simplest energy-related improvements.

For traditional buildings, it is clear that non-intrusive upgrading measures such as draught proofing, attic or loft insulation and boiler replacement can ensure that a traditional building has the potential to out-perform a newly built building over a lifetime of one hundred years.

Upgrading Option	Estimated Payback Period	Cost Bracket
Insulation: Hot water tank	6 months	Low
Insulation: Lagging to hot water pipework	1 year	Low
Draught proofing windows and doors	1 year	Low
Insulation: Loft	2 years on average but dependent on materials used	Medium
Upgrading to high-efficiency boiler with correct controls	Less than 8 years	Medium (changing from a 70% to a 90% efficiency boiler would result in typical savings of approximately €300 per year)
Insulation: Suspended timber floors	2 years	Medium
Adding front porch	30 years	High
Installing double glazed windows	40 years	High

Cost and Payback Periods

The energy efficiency improvements indicated above include simple actions such as installing a hot water cylinder jacket and draught proofing windows. The price and effectiveness of various upgrading measures will vary for any given building. Available options are discussed in more detail in Chapter 3. This chart gives a rough indication of typical cost and payback periods for different interventions. These are a guide only and will vary with individual properties, and will reflect, to a certain extent, the quality of materials and workmanship employed (Source: SEAI)

Conservation principles

In a sense, we look after our historic buildings not only for ourselves but for those who come after us. Many of these buildings have been around for generations before us and it is our responsibility to hand them on in good condition to allow future generations to enjoy them too. So that the works you undertake do not damage the special qualities of a historic building, it is important to understand some of the basic principles of good building conservation. Many of these are common-sense and all are based on an understanding of how old buildings work and how, with sensitive treatment, they can remain special.

Before you start, learn as much as you can about your particular building. What is its history? How has it changed over time? Remember that later alterations may be important too and evidence that the building has been cared for and adapted over the years with each generation adding its own layer to a unique history.

CARRYING OUT MAINTENANCE OR REPAIR WORKS

- > Do use the experts - get independent advice from the right people
- > Do establish and understand the reasons for failure before undertaking repairs
- > Do repair the parts of the building that need it - do not replace them unless they can no longer do the job they were designed to do
- > Do make sure the right materials and repair techniques are used and that even the smallest changes you make to the building are done well
- > Do use techniques that can be easily reversed or undone. This allows for any unforeseen problems to be corrected in future without damage to the special qualities of the building
- > Do record all repair works for the benefit of future owners

- > Don't overdo it – only do as much work to the building as is necessary, and as little as possible
- > Don't look at problems in isolation – consider them in the context of the building as a whole
- > Don't use architectural salvage from elsewhere unless you are certain that the taking of the materials hasn't caused the destruction of other old buildings or been the result of theft

2. Understanding the Building

Fundamental to best practice in building conservation and in sustainability is a good understanding of the behaviour and nature of traditional buildings, the design choices made in their construction and the way traditional buildings relate to their environment.

The effects of climate

SETTING RELATIVE TO LANDSCAPE

Many early builders were aware of the advantages of practices such as building in sheltered locations and of planting trees to form shelter belts. It is therefore important to acknowledge the impacts of exposure to both wind and sun, and of latitude and altitude on an existing building, and to assess how the immediate setting of the building might be changed to improve the microclimate in which a building exists.



A house in the countryside sheltered both by the local topography and by trees

TEMPERATURE RELATIVE TO LOCATION WITHIN IRELAND

Ireland has a temperate climate with modest extremes of minimum and maximum temperatures, whether considered for individual days, seasons or over an entire year. The average temperature when taken over the course of a full year is 10°C. Temperatures tend to be higher in the south-western areas of the country and lower in the midlands and north-east. According to *Green Design: Sustainable Building for Ireland*, for every 100m rise above sea level, temperatures drop by approximately 0.6°C. The difference between the ambient average external air temperature and a desired internal, or 'room', temperature of 21°C varies

throughout the country and therefore, the heating load for different locations varies. The heating load is the amount a building needs to be heated to reach the desired internal temperature of 21°C for living rooms and 18°C for other spaces. When thought of in terms of an annual amount, this heating load is expressed as 'degree days.' Degree days are a measure of climatic severity; by virtue of geographic location alone, there can be a difference of more than 30% in the heating load on identical buildings in different locations within Ireland. In effect, a well-insulated building in one part of the country has a requirement for heating more than a quarter greater than that of an identical building in another part of the country. The need for 21°C as a desirable internal temperature could be challenged; certainly lower air temperatures are acceptable where ambient surface temperatures are relatively high, when people are warmly dressed, and so on.

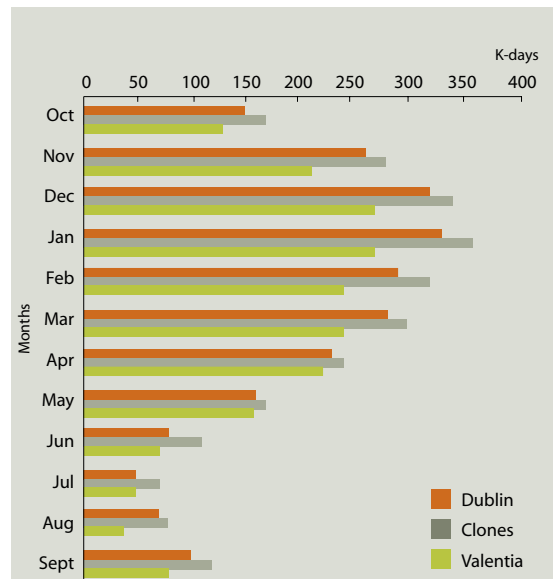

Monthly values for heating degree days

Degree days (or Accumulated Temperature Difference) are calculated by multiplying the number of degrees below a base temperature (in Ireland 15.5°C) on any given day by the number of days in a single year that the difference occurs. The base temperature of 15.5°C assumes an internal design temperature of 18.5°C for an unheated space with a temperature difference between exterior and interior of 3°C (Source: Green Design, Sustainable Building for Ireland)

WIND: SHELTERED OR EXPOSED

Ireland is an exposed island on the edge of a large ocean with high maximum and average wind speeds when compared to most other European countries. Wind conditions vary from place to place with pronounced differences on the coast and on high ground. Winds are strongly influenced by local topography: for example, rough terrain reduces wind speed. Similarly trees, vegetation, hills, valleys and water affect wind speed and, in consequence, the amount of heat lost from any adjacent buildings.

When wind blows across the external envelope of a building the rate of heat transfer to or from the building's surfaces increases. Wind can also affect heat gains or losses by infiltration (draughts) due to increased pressure or through defects in the building fabric. The importance of achieving shelter from cold and damp wind has traditionally been understood; the traditional selection of a location for a dwelling was often in the lee of a hill and, equally importantly, not in a hollow prone to frost. Where natural features did not provide sufficient protection, shelter belts of trees were often provided.



Houses on Great Blasket Island in lee of the hill with their gables turned towards the direction of the prevailing wind

Creating shelter on a site can reduce heat loss by up to 15% and reduce the wind chill factor for people outdoors. Notwithstanding any shading they may confer, a permeable barrier such as a stand of trees is efficient at reducing wind speed. According to *The Climatic Dwelling - an introduction to climate-responsive residential architecture*, protection by a stand of trees (with 40-50% permeability) can provide protection for up to seven or eight times the height of the trees. Shelter belts with under-planting, positioned perpendicular to the direction of the prevailing wind, can offer protection for up to 25 times the height of the trees provided that the shelter belt is at least 15 times as long as it is high. Interestingly, protection from a shelter belt also extends upwind for some distance, as the wind lifts up in advance of passing

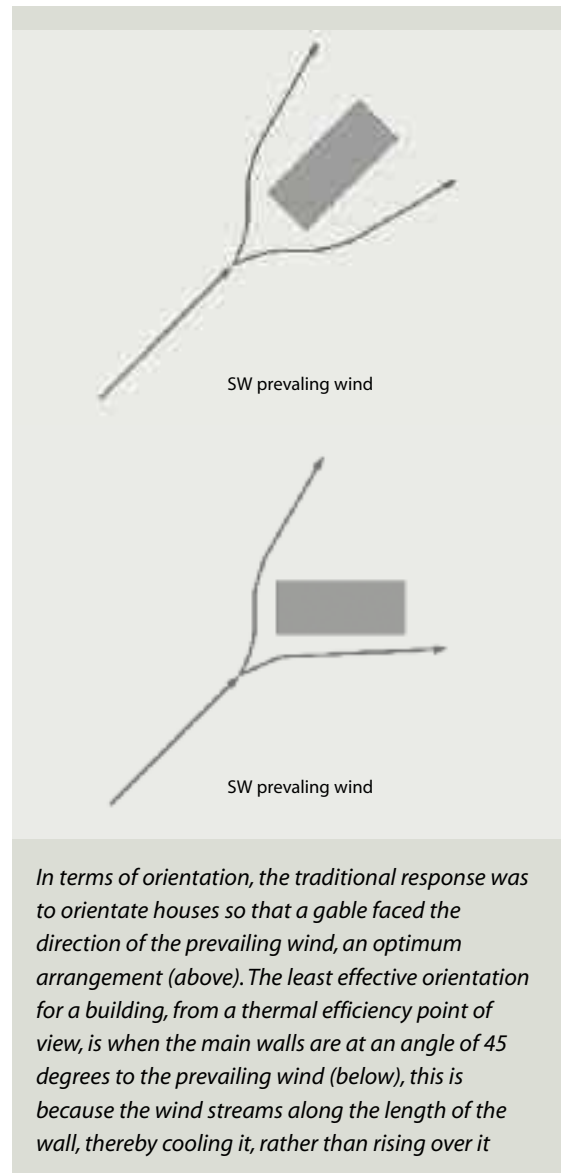

In terms of orientation, the traditional response was to orientate houses so that a gable faced the direction of the prevailing wind, an optimum arrangement (above). The least effective orientation for a building, from a thermal efficiency point of view, is when the main walls are at an angle of 45 degrees to the prevailing wind (below), this is because the wind streams along the length of the wall, thereby cooling it, rather than rising over it

over the obstacle ahead of it. In comparison, a solid wall is only effective for a distance of four to five times its height (from *Green Design, Sustainable Building for Ireland*). Solid obstructions to the wind can also create uncomfortable and disturbing turbulence whereas permeable barriers allow some air to move through the barrier and so create a smoother airflow pattern. Where they exist, outbuildings can provide shelter to the main house in addition to providing shelter to the outdoor working or recreation areas. While it is true that wind direction constantly changes so that no single orientation provides a complete solution, when the direction of the prevailing wind is taken into account it allows an optimum orientation to be identified.

All the above are approaches to modifying the microclimate around a building, to the benefit of the building users, both within and around the building.



Traditional farm complexes were arranged so that the buildings provided shelter, not only to each other, but also to the outdoor working areas

HUMIDITY

There is little empirical information available concerning the impact of humidity or dampness on overall heat loss, but it is widely understood that energy is expended in reducing high levels of humidity and that heat loss is greater when heat passes through damp materials: damp socks are colder than dry ones! When humidity is high, comfort levels can normally be achieved during winter months by raising the air temperature and during the summer months by increasing ventilation. Humidity can be reduced mechanically but dehumidifiers are energy-hungry and should be used sparingly. The beneficial role that traditional finishes such as lime plaster and timber play in moderating humidity is now being appreciated.

Activities within a building, such as cooking, showering, and clothes and dish-washing, generate moisture and can raise humidity levels. Even the act of breathing releases moisture into the air. It is possible to limit the effects of excessive water-vapour within a building. Control may relate to simple actions; solutions such as using well-fitting lids for saucepans not only save energy in cooking, but also prevent vapour escaping, which would otherwise condense on cold surfaces. Ventilating close to the source of moisture, such as in the shower or over the hob or sink, is the best solution. However, the impact on a protected structure or a building within an architectural conservation area of new external wall vents requires careful consideration so as to avoid any adverse impacts; such works may require planning permission.

SOLAR RADIATION/SUNLIGHT

The course of the sun is predictable for any given day of the year. This allows for a full understanding of the impact of the sun on a building or site. In Ireland, about 40% of the sun's radiation is direct and 60% diffuse, that is, scattered by cloud cover. Harnessing of the sun's energy offers huge potential and can be used effectively for passive and active heating and daylighting.

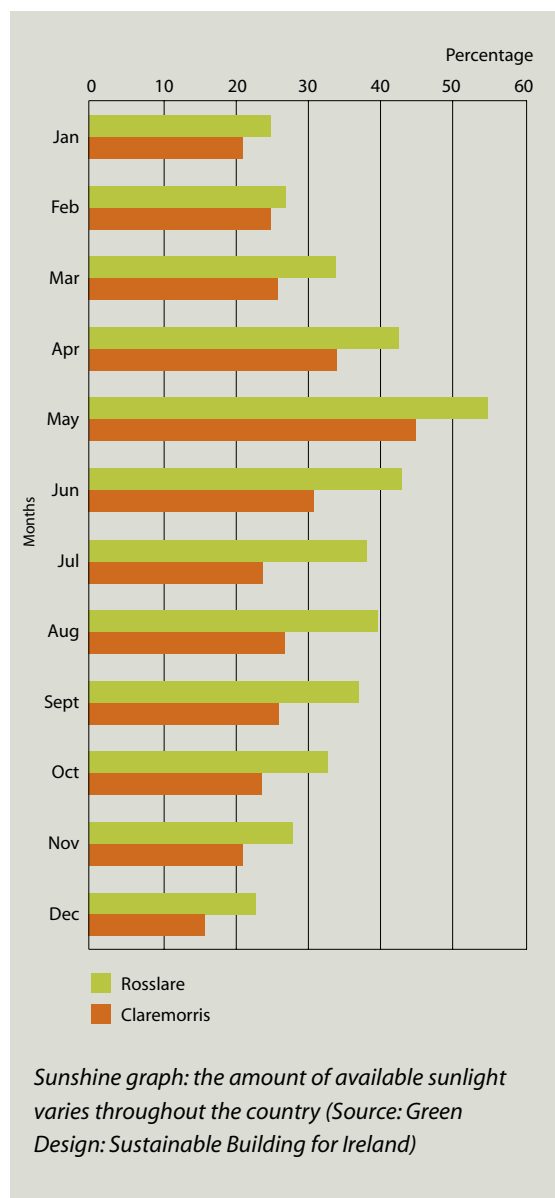

HEATING SEASON

The heating season is the period during which the external temperature drops significantly below comfortable internal temperatures, requiring some form of space heating within buildings. In Ireland, the heating season extends for a period of about 220 to 260 days, from mid autumn through the winter and into late spring.

During the heating season, heat within a building can come from a variety of sources. While heating appliances such as stoves, central heating and open fires are the main sources, a certain amount of heat is also gained from electrical appliances, televisions, computers, washing machines, lighting and indeed from the occupants of the building.

Solar gain, the heat absorbed by a building from the sunshine which falls on it, can have a positive impact on space heating requirements if properly used. During the heating season while heat is gained from the sun it is simultaneously being lost through heat transfer from the interior through the building fabric and through air infiltration. However, solar gain can be high for the spring and autumn months which fall within the heating season, when the sun is low in the sky and thus able to penetrate further into the interior of the building through windows. At these times of the year, solar gain can make a significant difference by raising internal temperatures and by providing a sense of comfort through radiant heat.

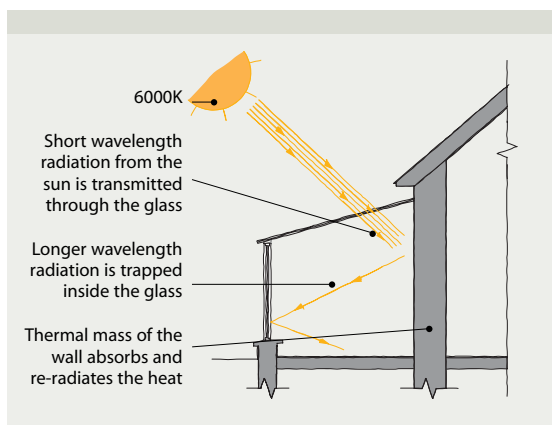

Solar gain: the 'greenhouse' effect. Traditionally, conservatories and greenhouses were built to maximise the advantages of the heat from the sun; sunlight entering through the glass warmed the air inside allowing for the cultivation of exotic flowers and fruits. The conservatory also provided a room for entertaining which was a place of transition between the house and garden

COOLING SEASON

Traditionally, the mechanical cooling of buildings has not been a requirement in Ireland's temperate climate. However, cooling sometimes becomes necessary in office environments, even in traditional buildings, where the amount of heat generated by electronic equipment can be substantial, and is usually emitted during the day when external temperatures are at their highest. The thermal mass of the traditional building tends to modify the cooling requirement, allowing the use of natural ventilation to achieve comfort levels. In this regard the traditional vertically sliding sash window offers a highly adjustable solution to ventilation, its top and bottom opening providing an optimum arrangement.

Planning for warmth

PASSIVE DESIGN

In general, passive design means ensuring that the fabric of the building and the spaces within it respond effectively to local climate and site conditions so as to maintain comfort for the occupants with the minimal use of energy. In new buildings this can be taken to its ultimate state where buildings are so well insulated and sealed against uncontrolled air infiltration that no heating appliances are required. For a number of reasons, this is neither achievable, nor indeed desirable, for traditionally built buildings which need good ventilation in order to maintain the building fabric. Nonetheless, it is obvious that past generations of builders had an inherent understanding of the thermal behaviour of a building in its setting; traditional buildings often portray many of the principles of modern passive design in their location, orientation and overall design.



Trinity College Library, Dublin. There were never fireplaces in the library, to avoid the risk of fire breaking out. Sunlight streams in through large single-glazed south-facing windows, maximising solar gain. Appropriate steps should be taken to protect light-sensitive historic furnishings and contents from damage caused by both ultra-violet light and visible sunlight

BUILDING ORIENTATION AND SHAPE

During daylight hours, buildings gain heat from the sun through windows. The amount of heat gained depends on the orientation, time of year, amount of direct sunlight or cloud cover, the type of glass in the windows and the nature of the materials within the building. While, generally speaking, south-facing windows provide most benefit from the sun, east and west-facing windows also facilitate large, useful solar gain. When the sun is low in the sky, during the cooler seasons and early and late in the day, sunlight penetrates deeper into the interior of a building, providing a valuable source of heating energy. When sunlight falls on a solid internal surface, one with high thermal mass such as a wall or floor, it heats it. This heat later radiates back out of the wall or floor, providing a free source of extra warmth within the building. Large windows in many traditional buildings encourage the use of daylight, reducing the need for artificial lighting. Arising from this, it is clear that the overall shape and design of a building determine the extent to which its occupants benefit from solar gain.

In order to use solar gain to its full advantage, room uses and activities should correspond to periods of sunshine; generally bedrooms and kitchens should face east to benefit from the morning sun and living rooms and dining rooms west, for evening use. In larger houses, where the possibility of choice exists, cooler north-facing rooms could be used primarily during the summer. Appropriate use of space is also important. Peripheral spaces can be left unheated (or with minimal heating) and unused during the colder months of the year; unheated conservatories and sunrooms fall into this category. Where there is an existing conservatory it should be left unheated and preferably thermally separated from the main house with a door.

In general, the greater the area of exposed surface a building has, the greater the amount of heat loss that occurs. Physically attaching buildings one to the other is therefore immediately advantageous, as the area of wall exposed to the elements is significantly reduced, notionally by about a half in a terraced building, and by about a quarter in a semi-detached one.

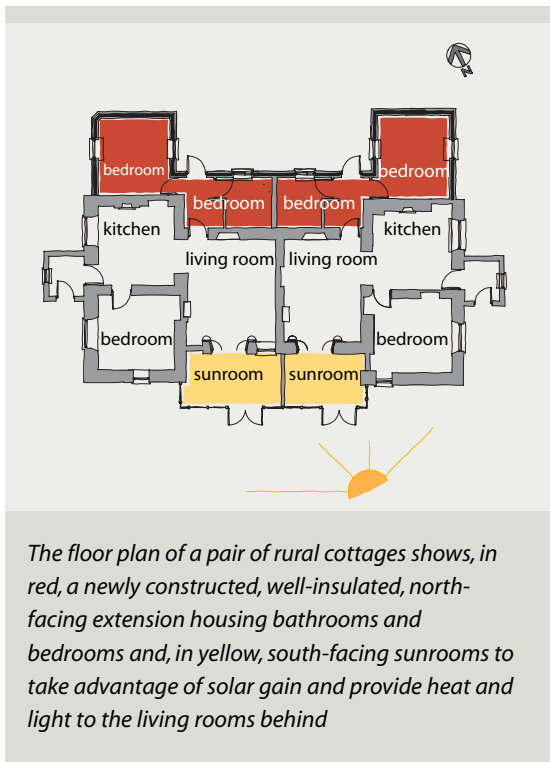

PATTERNS OF USE

The extent to which a building is used, and the pattern of that usage, changes its energy requirements. Take, for example, two identical houses: one with a young family who occupies the house during the day and the other with a single person who is out at work all day. The required space heating varies greatly between the two buildings. Similarly, buildings used for domestic and commercial purposes produce very different amounts of heat. Therefore, the heating solutions for buildings should reflect an understanding of the patterns of use of the building. In addition, the number of appliances being run in a building has an impact on the space heating requirements. In a commercial building, the heat generated by computers and artificial lighting reduces the amount of heat to be provided by a heating system, sometimes resulting in a requirement for cooling. A domestic home with a large family running a number of heat-generating appliances, such as personal computers, televisions, computer games and washing machines, requires less space heating than a house with a single occupant, running fewer appliances.

Building use

In addition to all of the above, the way people perceive the comfort of a building is dependent on the building's use, the activities of its users and the nature of its interior furnishings.

PERCEPTION OF THERMAL COMFORT

Within the internal environment of a building there can be many reasons for a person's body temperature to change. These reasons can be broken down into two main factors: environmental and personal. Environmental factors include air temperature, the



Leather linings and tapestries line the walls of this room and improve the thermal comfort of the occupants



Box pews were the traditional way of keeping church-goers warm in an unheated, or poorly heated, church. The timber floor to each pew provided a warm surface underfoot, while the 'box' protected its occupants from draughts

temperature radiated by the surrounding building fabric, air movement and humidity. Personal factors include clothing, activity level, body weight and age: new-born infants and elderly people generally require greater warmth.

Preventing loss of heat and excessive air movement helps maintain a comfortable internal air temperature. The temperature of the interior surfaces within a room is as important as the temperature of the air within a room. Colder surfaces such as stone walls, stone or tile floors and glass which are slow to heat up can give the perception of a cold environment, leading to a feeling of discomfort. Traditionally, these problems were overcome with curtains, tapestries, wallpaper and timber panelling. Similar solutions are still applicable today, perhaps even on a seasonal basis. The use of folding screens within a large room, or even the use of more permanent linings can be considered where appropriate. The installation of permanent linings in a protected structure may require planning permission.

Heat loss from buildings

Heat is lost from the interior of a building in two main ways: by transfer through the materials that make up the external envelope of the building (measured as a U-value) or by the exchange of air between the interior and the exterior environment that is, ventilation.

It is estimated that typical heat losses from a building are as follows:

- > Walls 35%
- > Roofs 25%
- > Floors 15%
- > Draughts 15%
- > Windows 10%

Heat transfer through building materials

U-VALUE

The rate at which heat is transferred through the external envelope of a building is expressed as a U-value. Heat always flows from a warm area to a cold area and each material component of the external envelope of a building transfers heat at different rates. The slower a material transfers heat, the better it is as an insulator. Low U-values are given to those materials that transfer heat slowly and are therefore good insulators; thus lower U-values are better. For any given construction, independent of U-value, heat loss is also directly related to the temperature difference between the exterior and interior, and, to a lesser degree, the colour and texture of the external walls.

Moisture reduces any material's ability to insulate, as the conductivity of material increases when damp and with it the U-value; even moderate changes in dampness can significantly increase an element's U-value, reducing its insulating properties. Common causes of moisture ingress include damp penetration in walls due to defective or removed render, leaking gutters and poorly fitting windows frames. It is therefore important to ensure that buildings are well maintained and weather-proofed to achieve low U-values.

Calculating U-values

This process requires some technical know-how. An owner rarely needs to be able to calculate U-values for a building but it may be useful to understand the process and how it might be applicable to works that are undertaken to improve energy efficiency.

The first step is to establish the thermal conductivity k (W/mK) of each material in the construction: this is done by reference to published tables. Next calculate the thermal resistance R (m²K/W) for each material as follows:

$$R = \frac{t}{k} \text{ (m}^2\text{K/W)} \quad \text{where } t \text{ is the thickness of each material.}$$

The U-value of a building element made of multiple layers is given by:

$$U = \frac{1}{(R_1 + R_2 + R_3 + \dots + R_g)} \text{ (W/m}^2\text{K)}$$

As U-values are calculated based on a notional fixed temperature difference between inside and outside, they remain constant for a given type and thickness of material; the U-value does not normally take into account orientation or exposure, although a refined evaluation of overall heat losses for windows gives radically different values depending on whether a window is north or south facing.

While overall heat loss calculations can be adjusted for emissivity (the extent to which a body reflects or radiates heat) of the internal and external surfaces, it is more difficult to adjust calculations for material defects or climate variations (such as a chilling wind), both of which increase the rate at which heat is lost through a building's shell.

Tables giving U-values for common construction types are available from the Sustainable Energy Authority of Ireland (SEAI). Simple software for calculating U-values is also available. Manufacturers of insulating products normally indicate the U-value on the product literature. However, this data must be verifiable if it is to be used in calculations. The appropriate European Standard or keymark (for example BSI) should also appear on the literature to enable traceability.

U-values for works governed by the Building Regulations in existing buildings can be found in Technical Guidance Document L of the Regulations.

Thermal bridging

Thermal bridging, also known as 'cold bridging', occurs at locations where part of an external wall, floor or roof, draws heat directly to the outside at a faster rate than surrounding materials. In the interior, these thermal bridges are cooler than the surrounding building material and therefore attract condensation, often leading to mould growth. Any proposed insulation works should ensure that all parts of a room are insulated consistently to avoid thermal bridging. It should be noted that higher insulation levels can exacerbate issues related to thermal bridging as the temperature difference between the insulated areas and any remaining thermal bridges will be greater, allowing a concentration of condensing moisture to occur on the thermal bridge.



This plastered ceiling has no insulation above it. Discolouration can be seen on the plasterwork between the timber joists located above, as the timber is slower to transfer heat to the cold roof space than the plaster alone. Dust particles in the warm air passing through the plaster remain trapped on the surface causing the discolouration

Ventilation and indoor air quality

All buildings require ventilation but traditional buildings require somewhat higher rates of ventilation than modern construction. Ventilation allows the moist air produced by the occupants themselves - through expiration, by cooking, by bathing and showering and domestic washing - to escape before it causes harm to the building fabric and furnishings. Ventilation also plays an important role with regard to the health of the occupants, ridding buildings of indoor air pollution associated with health problems

including allergies, asthma, infectious diseases and 'sick building syndrome.' Many indoor air pollutants are thought to be the result of increased use of solvents, cleaning agents, office appliances and the like. Ideally, there should be a regular purge ventilation of the air within buildings, opening windows fully for about ten minutes a day where possible. Rooms with open fires and open-flue appliances must have a sufficient air supply to avoid a dangerous build-up of carbon monoxide. Where draught-proofing programmes are proposed this must be taken into consideration. Installing new vents may have implications for the external appearance of the building. It requires careful consideration to avoid adverse impacts, and may require planning permission.

In modern buildings, ventilation is generally controlled to some extent; extraction fans in kitchens and bathrooms remove moisture at the source of its production while 'trickle ventilation' through window and wall vents allows a steady but controllable ventilation flow. In traditional buildings, ventilation comes from a variety of sources, with air being admitted down open chimney flues, through roofs and at the edges of doors and windows.

While all buildings require some level of ventilation, traditional buildings require ventilation for one further and very important reason. Solid walls were generally constructed using soft porous and breathable materials that absorb and release moisture on a cyclical basis, becoming damp during wet weather and drying out when conditions are finer. Traditionally, moisture which migrated through the full depth of a wall was dissipated by the high levels of ventilation created by the use of open fires which drew air into the building and out through the chimneys. Where this ventilation flow is significantly reduced by the sealing up of flues and windows, or by the use of dense cement or plastic-based impermeable coatings to walls, damp conditions can develop, with the potential for mould and fungal growth to flourish. In addition to being unsightly, high levels of mould growth can cause or aggravate respiratory illnesses particularly in the young and elderly. If the lack of ventilation is allowed to continue unchecked, it will increase the risk of dangerous levels of moisture building up in structural timbers, making them vulnerable to fungal and/or insect attack and will lead to deterioration of internal finishes, necessitating redecoration. It is therefore important that any alterations to a traditional building provide for the continuing ventilation of the building fabric to the necessary levels.

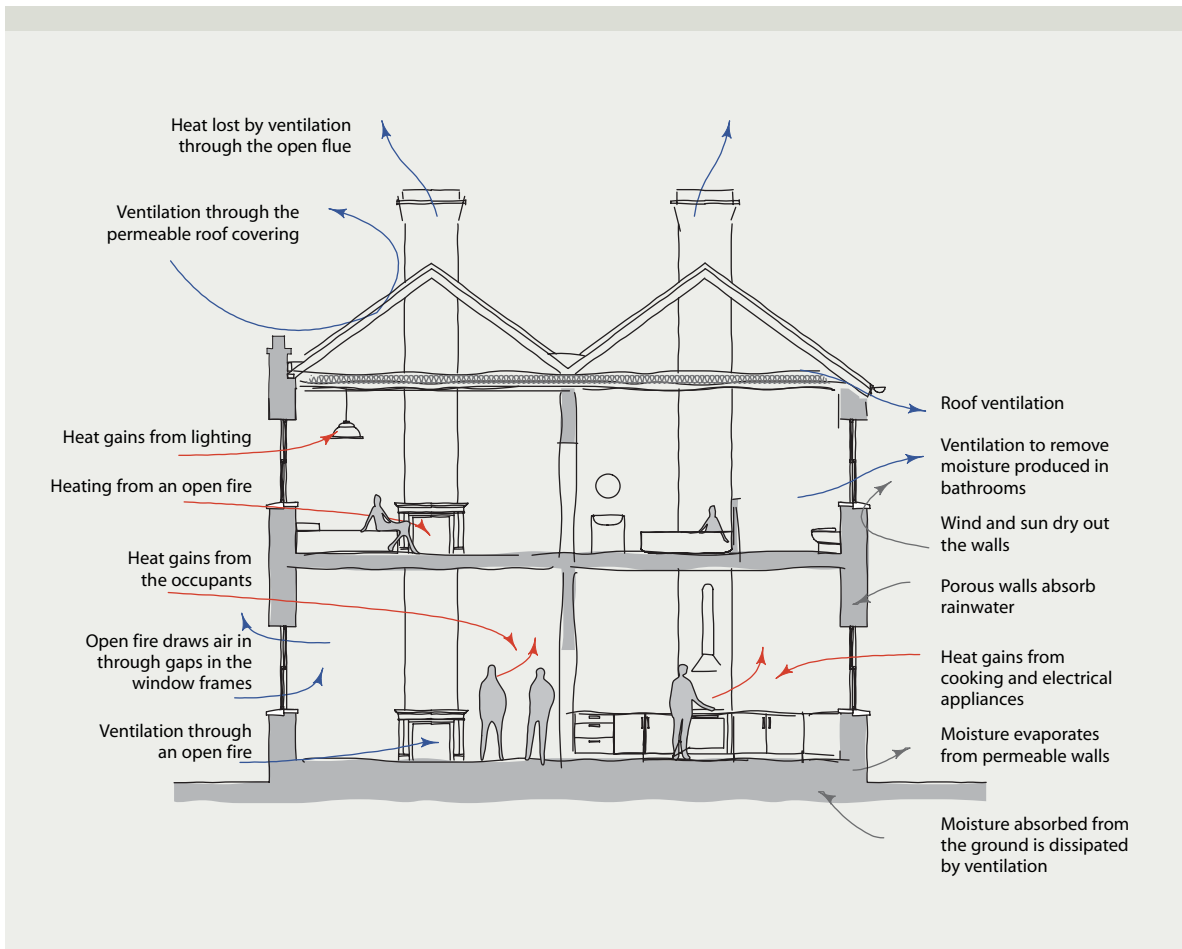

A comparison of the ventilation and heating requirements for a traditional building (above) and a modern building (below)

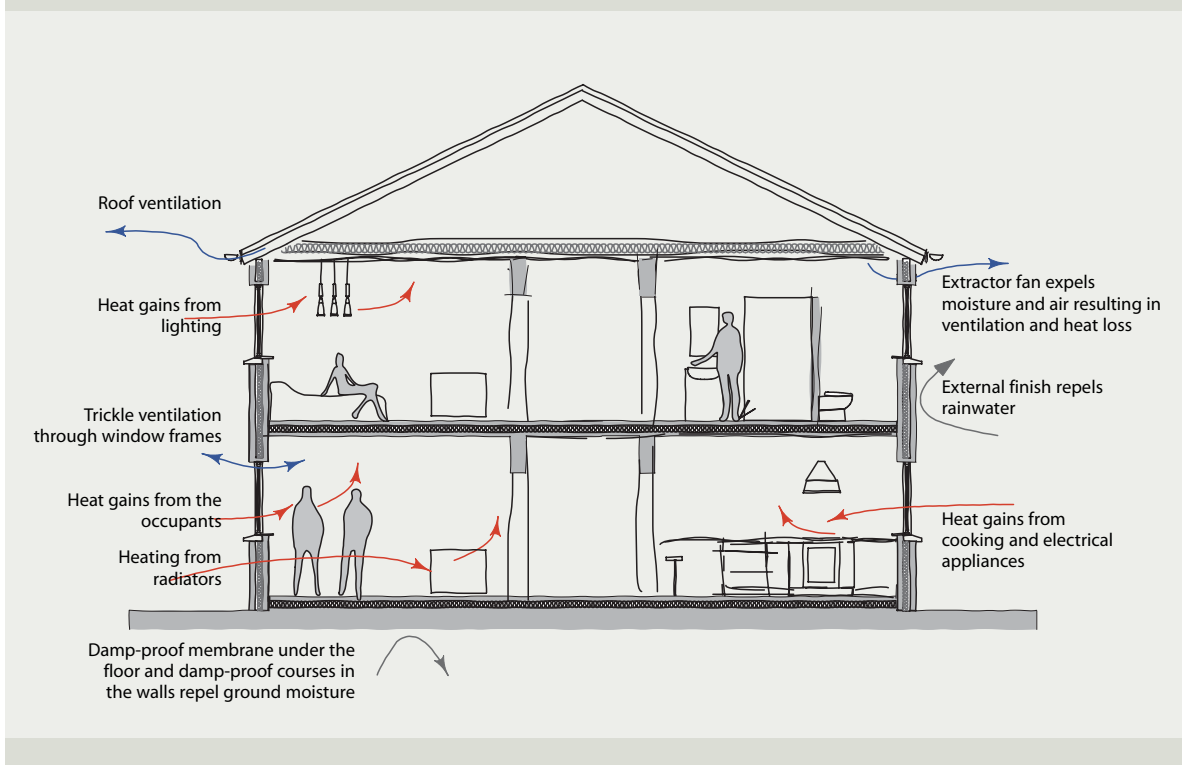

Thermal mass

Different materials absorb and radiate heat at different rates. Thermal mass is the ability of high-density materials such as brick and stone to absorb heat, retain it and then release it again slowly over time, helping to moderate the temperature fluctuations within a room. Thermal inertia is the term used to describe this process. A thermally lightweight structure responds very quickly to solar gain or central heating and is less effective in storing free energy for use later, and can result in larger temperature swings within a room.

Depending on the orientation and size of the windows in a building, the use of passive solar gain is improved in buildings that have a high thermal mass, arising from their overall construction; for example masonry internal and external walls and solid floors allow a building to absorb, retain and later release the heat absorbed from the sun. The possibility of effectively exploiting solar gain in a building of high thermal

mass is optimised if a building is occupied during daylight hours, when the occupants can take full advantage of the free stored heat.

It should be noted that a heavy masonry wall and a well-insulated lightweight structure with the same U-value (rate of heat loss) have very different responses to internal space heating. It may well be suitable that a building should respond quickly to heat or cold, but in general it is accepted that for traditional buildings high thermal mass and a relatively slow response time are advantageous.

While traditional buildings tend to have high thermal mass, their occupants frequently fail to exploit this potential as the buildings may be uninsulated and draughty. However, when one addresses these shortcomings, traditional buildings can have desirable qualities and can efficiently provide comfort and warmth for their occupants.

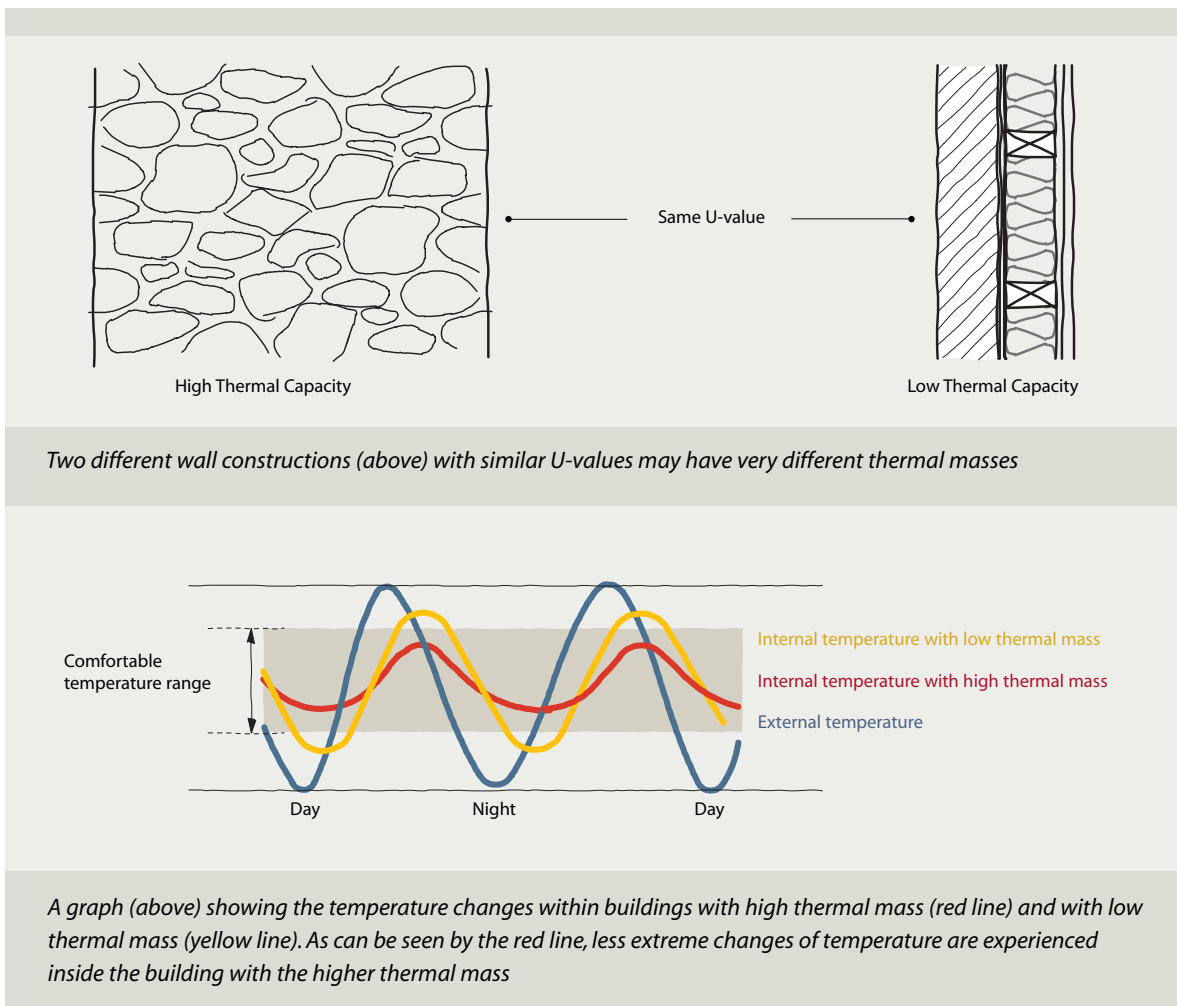

A medieval tower house with thick stone walls and a high thermal mass (above) and an unusual lightweight timber building with low thermal mass (below)



Assessment methods

There are a number of non-destructive techniques available to assess the energy efficiency of an existing building. These range from the use of simple hand-held devices such as moisture meters and borescopes to more complex and expensive methods such as thermal imaging. Expert knowledge and experience will be needed to decide which assessment method is appropriate in a particular case, to undertake the assessment and to interpret the results.

THERMOGRAPHY

Thermography, or thermal imaging, is photography using a camera that captures infra-red (IR) light rather than the visible light captured by a standard camera. IR light occurs beyond the red end of the visible light spectrum and is invisible to the naked eye. All objects that are warmer than absolute zero (-273°C) emit IR light. The warmer the object is, the more IR light it emits. IR cameras record the amount of IR light emitted by an object and translate it into a temperature which is indicated on a scale bar adjacent to the thermal image or thermogram. Even very small temperature differences, as low as 0.1°C, can be recorded by IR cameras. The image produced by an IR camera is multi-coloured with each colour representing a different temperature. Different colour scales can be used depending on the objects photographed. Thermography has many varied applications in different disciplines and can be a useful tool when assessing the condition of a building. It has particular advantages for investigating historic buildings as it is a non-invasive, non-destructive method.

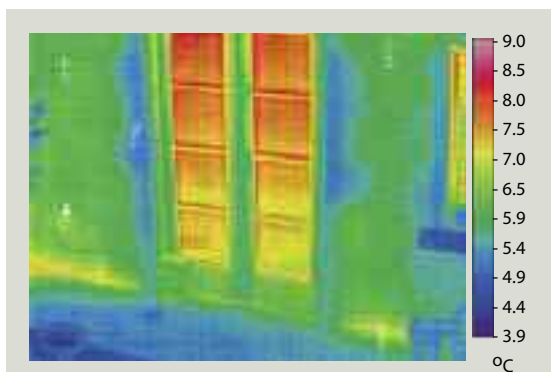

A thermographic image of a double-glazed door at semi-basement level in a nineteenth-century terraced house; note how the yellow patches at the base of the wall, which are damper, indicate that these areas are emitting heat at a higher rate than the rest of the wall

Thermal imaging can be used to identify potential problems with a building's fabric. When looking at traditional buildings, thermal imaging might be used to identify areas of dampness and to locate thinner depths of wall, cracking and voids. Expertise is required both in deciding how and when to take IR images and later in interpreting the information. For example, objects which have high or low emissivity such as metal do not give an accurate temperature reading. Weather conditions, orientation and the time of day when the image was taken all have the potential to affect the reading. The information gathered from thermal images can be properly assessed only in conjunction with data gathered as part of a comprehensive condition survey.

AIR-PRESSURE TESTING

Air-pressure testing, or fan-pressurisation testing, assesses the air-tightness of a building and the rate of air leakage occurring through the fabric. Modern building methods seek to 'build tight and ventilate right.' However, as discussed elsewhere in this booklet, this maxim is not appropriate for traditional buildings which require relatively high levels of natural ventilation to keep the building fabric in good condition. Nonetheless, testing a building's air-tightness may highlight areas or points of particularly high air leakage which could be remedied without compromising the health of the building fabric. Care should be taken when undertaking air-pressure tests on older buildings which contain fragile building elements, including delicate glazing bars and thin, hand-made panes of glass which would be damaged if subjected to excessive pressure.

ENDOSCOPY OR REMOTE VISUAL INSPECTION

Inspections of concealed parts of a building's construction can be carried out using a borescope or fibrescope, generally with minimal disruption to the building. This type of inspection can be used to investigate walls, roofs and floors for hidden defects by inserting a borescope or fibrescope into a small inspection hole. In the interior of a protected structure, the drilling of an inspection hole should be carried out with care and a location chosen that avoids any adverse impacts. In some cases, drilling through the building fabric may be unacceptable.

Such an inspection can be used as a follow-up to a thermographic survey to investigate the exact cause of heat loss through a particular part of the building fabric. The results of the inspection can be photographed or videoed on a camera attached to the system.

MOISTURE MEASUREMENT

Electrical moisture meters can be useful in detecting the presence of moisture in building fabric. Simple electrical resistance meters are relatively cheap, easy to use and widely available. However, the results can be inaccurate and misleading. False, elevated readings can be obtained, for example, where there are concentrations of salts on the surface of a wall, foil behind plasterboard, condensation and the like. Moisture meters are most useful and reliable when used on timber.

While the results need to be treated with caution, some useful information can be obtained from the use of a moisture meter. A number of readings taken across a surface can give a pattern of moisture levels. Localised high readings in the middle of a wall may indicate a building defect that has allowed rainwater penetration.

IN-SITU U-VALUE MEASUREMENT

Other assessment methods are available which include the measurement of U-values (the rate of heat transfer through a material) on site using a combination of thermography and a heat flux meter. There are international standards for making these site measurements. This is an expensive and complex assessment method that requires considerable expertise both to undertake and to analyse the resulting data.

RADAR

Examination of a building with radar uses low-power radio pulses to determine the make-up and condition of a structure. It can be used successfully on most construction materials to locate and measure voids, cracks, areas of corrosion and discontinuities in walls or floors and to detect the presence of old chimney flues. As with in-situ U-value measuring, the use of radar is a relatively expensive and complex assessment method that requires expertise to undertake and to analyse the resulting data.

ULTRASOUND

Ultrasonic scanning involves the use of high-frequency sound waves to provide a cross-section through a material. It can be used across very fragile surfaces without causing damage which makes it particularly suited to use on sensitive historic buildings. This non-destructive technique can be used in the investigation of timbers to determine if there is any decay present and, if so, its extent. It can also be used to assess the structural integrity of timber joints and the presence of zones of weakness within stone blocks. A high level of skill and experience is needed to carry out the assessment and interpret the results.

Building Energy Rating (BER) and traditional buildings

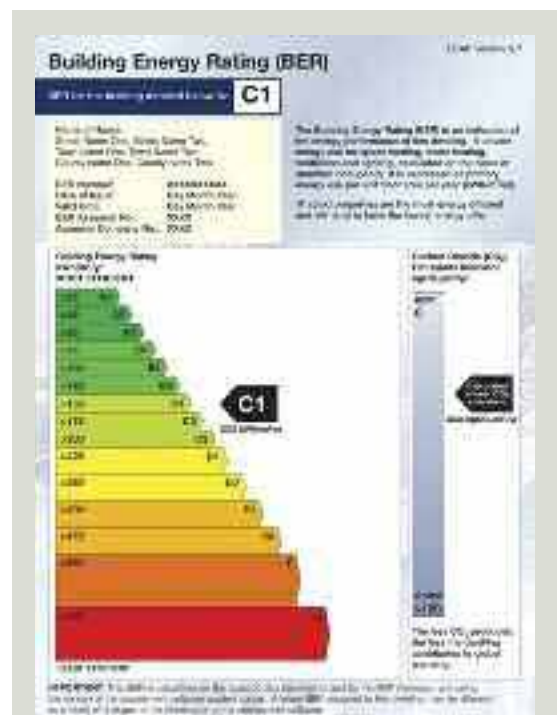

Sample Building Energy Rating Certificate for dwellings. The most energy efficient rating is 'A1' (green) down to the least efficient is 'G' (red)

The European Directive on the Energy Performance of Buildings promotes energy efficiency in all buildings within the European Union. One of its requirements is that all new and existing buildings within the EU have an energy performance certificate. The implementation

of performance certificates in Ireland is managed by the Sustainable Energy Authority of Ireland (SEAI) and takes the form of Building Energy Ratings (BER) for all building types, calculated by the Domestic Energy Assessment Procedure (DEAP) for dwellings and by the Non-domestic Energy Assessment Procedure (NEAP) for other building types. Public buildings greater than 1000m² are also required to have Display Energy Certificates.

BER certificates are now required for all new buildings and, in the case of existing buildings, for premises undergoing transaction, whether lease or sale. While buildings protected under the National Monuments Acts, protected structures and proposed protected structures are exempt from the requirements to have a BER, all other traditionally built buildings are required to have a BER certificate when let or sold. There is no requirement that a building achieve a particular rating. The BER assesses the energy performance of the building, allowing potential buyers and tenants to take energy performance into consideration in their decision to purchase or rent a property.

Following assessment of the building by a trained assessor, a certificate is prepared and issued to the building owner. The energy rating displays both the energy requirement of the building in terms of 'primary energy' and the resultant carbon dioxide emissions. Normally a building owner thinks in terms of 'delivered energy.' Delivered energy corresponds to the energy consumption that would normally appear on the energy bills of the building. Primary energy includes delivered energy, plus an allowance for the energy 'overhead' incurred in extracting, processing and transporting a fuel or other energy carrier to the building.

The objective of BER is to provide an energy rating for buildings, expressed in a familiar form similar to that used for energy-rated domestic appliances such as fridges, based on a standard system of appraisal which allows all properties to be compared regardless of how they are used or occupied. In the assessment methodology, the size and shape of a building are taken into account and its floor area determines the number of occupants that are assumed. The rating is based on a standardised heating schedule of a typical household, assuming two hours heating in the morning and six in the evening. A building's BER does not take into account its location within the country (whether in the colder north or warmer south) but

does consider orientation relative to the sun. It is also important to bear in mind that it does not take into account an individual household's energy usage but assumes a standardised usage.

At present, the standard calculation for older buildings relies on default values for heat loss calculations. These defaults are conservative and at times may poorly represent an older building's ability to retain heat. For example, there is only one figure for all types of stone, whereas in reality different stone types lose heat at different rates. Embodied energy is currently not accounted for in the BER system; this is an issue that requires more research in order that the characteristics of historic buildings in energy terms may be fully appreciated and recognised.

On completion of a BER calculation for an existing building, the assessment software generates a list of recommendations for upgrading the building in the form of an advisory report. These recommendations have been generally designed for existing buildings of modern construction rather than traditionally built buildings. As the BER assessor is responsible for deciding which recommendations are appropriate for a particular property, it is important to ensure that the assessor understands how traditional buildings perform, as inappropriate recommendations could lead to damage of older building fabric. A building conservation expert should be consulted prior to undertaking any recommendations on foot of a BER certificate.

Getting the right advice

When it comes to carrying out works to a traditional building, regardless of its age or size, it is important to know when specialist advice is needed and where to find the right help. It is a false economy not to get the best advice before undertaking any works. Ill-considered upgrading works can damage a building in the long-term, devalue your property and may be difficult and expensive to undo.

You will need the right advice for the particular job. Sometimes you will require an architect, a surveyor or a structural engineer. You should ensure that any advisor is independent and objective, not someone trying to sell you something or with a vested interest in increasing the scale and expense of work. You need someone who understands old buildings, has experience in dealing with them and has trained to work with them. He or she should be knowledgeable and experienced in dealing with your type of building. Many building professionals and contractors are only involved with modern construction and may not know how to deal sympathetically with a traditional building. Do not choose a person or company based on cost alone. The cheapest quote you receive may be from the person who does not fully understand the complexity of the problem.

The interpretation and application of the more technical recommendations in this guide should be entrusted to suitably qualified and competent persons. When employing a professional advisor or a building contractor, check their qualifications and status with the relevant bodies and institutes first. Ask for references and for the locations and photographs of recent similar work undertaken. Do not be afraid to follow up the references and to visit other building projects. A good practitioner won't mind you doing this. If you see a good job successfully completed on a similar building to yours, find out who did the work, whether they would be suitable for the works you want to undertake and if the building owner was satisfied.

Be clear when briefing your advisor what you want him or her to do. A good advisor should be able to undertake an inspection of your property, recommend options for upgrading its energy efficiency, specify the work required, get a firm price from a suitable builder and oversee the work on site as it progresses. If your building is likely to need ongoing conservation and repair works over a number of years, your relationship with your advisor and builder will be important both to you and your building and continuity will be a great advantage. They will be able to become familiar with the property and to understand how it acts and will build up expertise based on your particular building.

The Royal Institute of the Architects of Ireland keeps a register of architects accredited in building conservation and will be able to provide you with a list. Similarly, the Society of Chartered Surveyors has a register of conservation surveyors. The Construction Industry Federation has a register of heritage contractors. The architectural conservation officer in your local authority may have information on suitable professionals, building contractors or suppliers in your area.

3. Upgrading the Building

Upgrading a building to improve its energy efficiency requires careful consideration if works are to be effective, economical and avoid damaging the historic character of the building.

Building management

The first step should be to consider how the building is used and managed. The greatest savings in energy consumption generally come from changing the way a building is used and the behaviour of its occupants. Some relatively simple measures can result in immediate benefits including:

- > Turning down thermostats by as little as 1°C (this can result in potential savings of 5-10% on a fuel bill)
- > Having shorter or more efficient running times for the heating system
- > Heating unused or seldom-used rooms only to a level sufficient to avoid mustiness and mould growth and keeping the doors to such rooms closed
- > Using energy-efficient light bulbs
- > Placing fridges and freezers in cooler rooms where they will consume less electricity
- > Closing shutters and curtains at night
- > Fitting smart meters to provide information on electricity usage and raise awareness of energy consumption
- > Ensuring that the correct use of heating controls is understood by the occupants on completion of any upgrading works and that instructions are passed over to the new owner when the building changes hands. A lack of understanding of the controls for a heating system can lead to significant inefficiencies in the use of fuel and energy
- > Using daylight for lighting rather than artificial lighting

SEAI and some energy providers provide details on further energy saving measures on their websites.

Building condition

The next step should be to consider whether or not the building is in a good state of repair: there is often little point in insulating or draught proofing if it is not. Generally dry buildings are warmer buildings: high moisture levels in the fabric of a building resulting from leaks or general dampness seriously reduce a building's thermal efficiency. A wet wall transfers heat from the interior of a building about 40% more quickly than a dry wall, resulting in much greater heat loss. It is therefore important to ensure that roofs, gutters and downpipes are well maintained. Similarly, soil banked up against a wall and the use of dense, impermeable cement renders can trap moisture in walls. Therefore, before embarking on upgrading works, the condition of the building should be inspected and any necessary maintenance and repair works completed. For further information, see *Maintenance: a guide to the care of older buildings* in this Advice Series.



The importance of maintaining rainwater goods in good working order cannot be over-emphasised. Not only will the water running down this wall cause rotting of the building fabric and damage to the interior in the short to medium term; the dampness in the wall will also cause it to transmit heat more quickly from the inside of the building making it colder and less thermally efficient

Preliminaries to upgrading

- > Assess which elements of the building require upgrading works and complete a list of proposed works. Based on this list, estimate the cost of upgrading and the potential energy savings that will result on completion of the works. Be clear as to the purpose of the works: is it to save money, to reduce the building's carbon footprint, or to improve comfort levels?
- > Consider the effect of any proposed works on the appearance of the exterior and interior of a building and ensure that no works will interfere with, or damage, important elements or decorative finishes or the historic character of the building as a whole
- > Bear in mind that the cheapest works with the greatest energy savings are draught proofing, attic insulation and upgrading the boiler and heating controls. These can often be carried out with a minimal impact on the appearance of a building or its historic fabric, although certain caveats apply
- > If works are to be undertaken on a phased basis consider targeting colder rooms first, such as north-facing rooms
- > Don't reduce ventilation too much; ventilation is needed for human comfort and to dispel moisture within a traditionally built building

Products and materials

Before any new materials are introduced into a historic building, they should be proven to work, ideally having been in use in Ireland for 25 years or more and be known to perform well and not to have any damaging effects on historic fabric. However, with the development of more environmentally friendly products in recent years, in response to a growing awareness of the negative aspects of many commonly used building materials, it is possible that there are superior products available which are both durable and environmentally sustainable and which have not been tested over a long period of time. Expert advice from a building professional specialising in historic building conservation will be required prior to specifying and using innovative products, as a full understanding of their characteristics, qualities, limitations and appropriate application is necessary. Untried and untested materials should not generally be used in a historic building. If their use is not possible to avoid, then it is important that they should be fully reversible, that is, that they can be removed at a later stage if problems arise without causing any damage to the historic fabric of the building.

It is important to ensure that any new materials introduced into the building comply with all relevant standards or have third party certification as to their suitability, such as NSAI Agrément Certificates. Performance issues relating to fire resistance, moisture ingress and infestation should be properly considered.

INSULATING MATERIALS

Many upgrading options involve the use of insulation. In choosing which insulation material to use the following should be considered:

- > Research all proposed insulation materials. There is a large variety of insulating materials available, many of which provide the same insulation properties but vary in price and material content. Materials which meet sustainability criteria should be identified: some artificial or plastic-based insulation materials may embody substantial amounts of energy. Account should be taken of the expected lifespan of the material and whether or not there are available alternative materials. Additionally, health aspects related to off-gassing (gases exuded by some materials), compaction over time, and the 'breathability' of the materials themselves need to be taken into consideration
- > In order to protect the character of buildings of architectural and historic interest, it is generally not appropriate to insulate masonry walls, because of the impact on an interior of dry lining or plastering, or on the appearance of an exterior through the use of external insulation systems, together with the difficulties of successfully detailing joints such as at eaves and windows sills
- > Any proposed insulation works should ensure that all parts of a room are insulated consistently to avoid thermal bridging. Higher insulation levels can exacerbate problems associated with thermal bridging
- > When choosing products, consider the results which can be obtained from different options in terms of both the financial investment and resultant energy savings
- > Quilt insulation can be in the form of mineral wool, sheep's wool or hemp. Mineral wool may compress and sag over time if it gets damp and is unpleasant to handle. Sheep's wool and hemp are advantageous as both allow any moisture which is absorbed to later evaporate: this means that these materials are less prone to compression in the long term. Wool, being a natural material and a by-product of the agricultural industry, can be seen to be environmentally friendly in itself, while hemp is a carbon-negative material, that is, it absorbs carbon as it grows and locks it away in the plant

- > Blown insulation, often made up of recycled paper and also known as cellulose, can be blown into spaces such as attics up to the desired level of insulation. However, care should be taken to ensure that all vents or ventilation routes remain unblocked when filling spaces with this type of insulation. Reducing levels of ventilation can result in damaging levels of moisture content building up in the roof timbers
- > While sheep's wool, hemp and blown insulation materials appear to be better on health and environmental grounds, their introduction is relatively recent and accordingly issues related to their use may not yet have been fully identified. Certification by independent, third party bodies, such as the NSAI, should ensure that the product chosen is suitable for use and will provide appropriate guidance for installation.

Upgrading works and health and safety issues

When commissioning or carrying out improvement works within an older structure, the building owner should be aware of the requirements set out in the Safety, Health and Welfare at Work Act 2005, the Safety, Health and Welfare at Work (Construction) Regulations 2006 and the Safety, Health and Welfare at Work (Exposure to Asbestos) Regulations 2006. Helpful guidance is provided on the Health and Safety Authority website www.hsa.ie.

Before embarking on works to improve the thermal efficiency of any property the following safety considerations should be taken into account:

- > Older buildings may contain hazardous materials that could be dangerous to a person's health such as asbestos or other contaminants. Asbestos can be found within man-made roof coverings, lagging on pipework, older sheet or tile flooring materials, WC cisterns and seats and other building components. In the course of general upgrading works interference with, or breakage of, such materials must comply with the requirements of current legislation and in certain cases must be removed by specialist licensed contractors. Professional advice should be sought to identify and remove such materials.
- > Certain materials such as fibreglass or mineral wool insulation should be handled carefully using gloves, masks, eye goggles and other protective garments to prevent harm caused either by inhalation or physical contact with the small fibres that make up the material, particularly as such materials are often fitted in attics and other poorly ventilated spaces.
- > There are serious health risks associated with lead paints where a painted surface is flaking or chipping or where it is disturbed. For absolute certainty as to the presence of lead paint, specialist laboratory testing should first be carried out.

Reducing draughts

CAUSES OF DRAUGHTS

In traditional buildings, heat loss commonly occurs as a result of excessive ventilation or draughts. Over time buildings move, settle and shrink causing gaps to open up in locations where there were none originally. This often happens at the junction between windows and their surrounding masonry, or between sashes and window frames, including shutter boxes. Previous alterations to the building and works to install or remove services may have left gaps and cracks that were never properly sealed. Localised decay may have resulted in gaps particularly around doors and windows. All these factors invariably result in increased levels of ventilation and draughts, resulting in discomfort for the building users as well as the loss of heat.

REDUCING DRAUGHTS

Measures to reduce draughts should be given careful consideration both on a room-by-room basis and in the context of the building as a whole. Consideration should be given to reducing excessive air flow through, and around, particular elements in a building. It may be possible to draught proof windows in rooms which have other sources of ventilation such as wall vents and open chimney flues. Windows in rooms with no other vents can be partially draught proofed but a strip of draught proofing should always be omitted, such as at the meeting rails of sash windows, to ensure continued ventilation. If this does not provide sufficient ventilation in a particular situation, the top sash could be fixed in an open position to provide a small gap, allowing trickle movement of air to circulate from the meeting rail to the top. The top sash can be secured in place with a block on the window frame and both the top and bottom sash should be locked into the side of the frame, as a lock at the meeting rail will not be usable.

Inflatable chimney balloons can be used to seal open chimney flues that are not in use. These have the advantage that, if their presence is forgotten and a fire is lit, they deflate and melt away within a very short period. Fully sealing a flue is not recommended. Sufficient ventilation is needed in the interior to keep the building fabric in good condition and for the health of the occupants. In addition, ventilation is

needed within the flue itself to allow any rainwater that enters the flue to evaporate; otherwise it might combine with the combustion products in the flue to create acidic conditions. Where it is proposed to install a chimney balloon it may be possible to insert an open pipe into the flue before inflating the balloon so that a sufficient passage of air is maintained between the room and the outside air, via the flue.

In rooms such as kitchens and utility rooms that require additional ventilation because of the presence of heat and vapour-producing appliances, mechanical ventilation should be provided to remove the moisture from the interior of the building before it causes damage. Where possible, unused chimneys can be employed in lieu of vents in the wall to provide mechanical or passive ventilation. The installation of new vents in external walls requires careful consideration and possibly planning permission.

Roofs

An estimated 25% of heat loss occurs through a building's roof. The scope for reducing heat loss from a historic building in a non-intrusive way is greatest at attic and roof level; fitting insulation at roof level can be one of the most cost-effective measures in improving thermal performance in a traditional building.

Both pitched and flat roofs in traditional buildings were generally constructed of timber structural elements. Flat roofs were traditionally covered with lead or copper, which are high-quality, long-lasting cladding materials. Older pitched roofs are generally covered with natural slate or tiles although some may originally have been thatched. Thatched roofs are comparatively rare today, although many more probably survive unseen under later corrugated iron roof coverings. Thatch, by its nature, is an excellent insulant and thatched roofs generally do not require the addition of insulation and in fact may deteriorate if inappropriately lined from below. For further information, see *Roofs – a guide to the repair of historic roofs* and *Thatch – a guide to the repair of thatched roofs* in this Advice Series.

Traditional buildings were not fitted with attic insulation at the time of their construction. Many have been upgraded since but there may be scope for improving the existing insulation levels in many

buildings. Where no attic insulation is present, the fitting of it is an easy and cost-effective way to improve a building's thermal insulation. Existing insulation can be left in place and added to, provided that it is dry. Damp insulation should be removed as it is no longer acting as an insulating layer. The cause of the damp should be investigated and dealt with before new insulation is installed.

The fitting of insulation should have no adverse effects on a traditional building provided that ventilation and moisture control are properly addressed. Necessary repair works for leaks or timber treatment for rot or insect attack should be completed prior to commencing any upgrading of insulation levels. Condensation on roof timbers or on the underside of a roof covering (on the backs of slates or on the underside of lead sheeting) indicates inadequate ventilation and this should be addressed prior to proceeding with any further insulating works.

It makes sense to install the maximum thickness of insulation possible in the space available without compromising the ventilation of the roof space. Ventilation is very important in roof spaces as it prevents insect attack and fungal decay in the roof timbers by moderating humidity and the moisture content of the timber. Prior to commencing any loft insulation, it is important to establish the location of the vents, if these exist, and to verify that they will not become blocked by any added insulation. Where actual vents do not exist, a sufficient amount of ventilation probably occurs at gaps at the eaves of the roof and in such cases, the insulation should be fitted so as to ensure a through flow of air under the eaves and into the roof space is maintained. While adding insulation to a roof space does not normally require any planning permission, additional roof vents may require permission, where the building is a protected structure or is located in an architectural conservation area.

Insulation should be fitted tightly between the joists or rafters as any gaps will compromise the insulation's effectiveness. Quilt or blown insulation compress to fit into the spaces to which they are added while specific rigid insulation has been developed for roofs with grooves cut into the board to allow it to be compressed between rafters and joists, thus reducing the potential for gaps if the board is not cut correctly.



A large roof space with no insulation above the ceiling; while the heat rising from the building interior may benefit the timber and other building materials in the roof space, a lot of energy is wasted in this way

UPGRADING PITCHED ROOFS

Attic and loft spaces within pitched roofs which are to be unheated can be insulated at floor level. If the attic is in use as a habitable space, insulation should be fitted above, between the rafters. A loft space can be insulated using quilt insulation. Where there is insufficient depth between the existing ceiling joists an additional layer of insulation can be laid on top to increase the total thickness. If the attic is not floored out for storage purposes, it is enough to lay the insulation between and on top of the existing joists, with provision for secure access to water tanks, and the like. It is particularly important to ensure that any access hatch to the attic or loft is well-fitting and insulated on the attic side.

It should be noted that many historic buildings, particularly those constructed in the eighteenth and early-nineteenth centuries, have relatively insubstantial roof and ceiling construction, relying on slight timbers configured in a particular way. Use of such attics for storage must take account of the structural strength of the existing timbers, with an awareness that damage can be caused to lath-and-plaster ceilings by deflection of the supporting joists. If storage is required in the loft space a careful structural analysis should first be undertaken to ensure there would be no resulting damage.

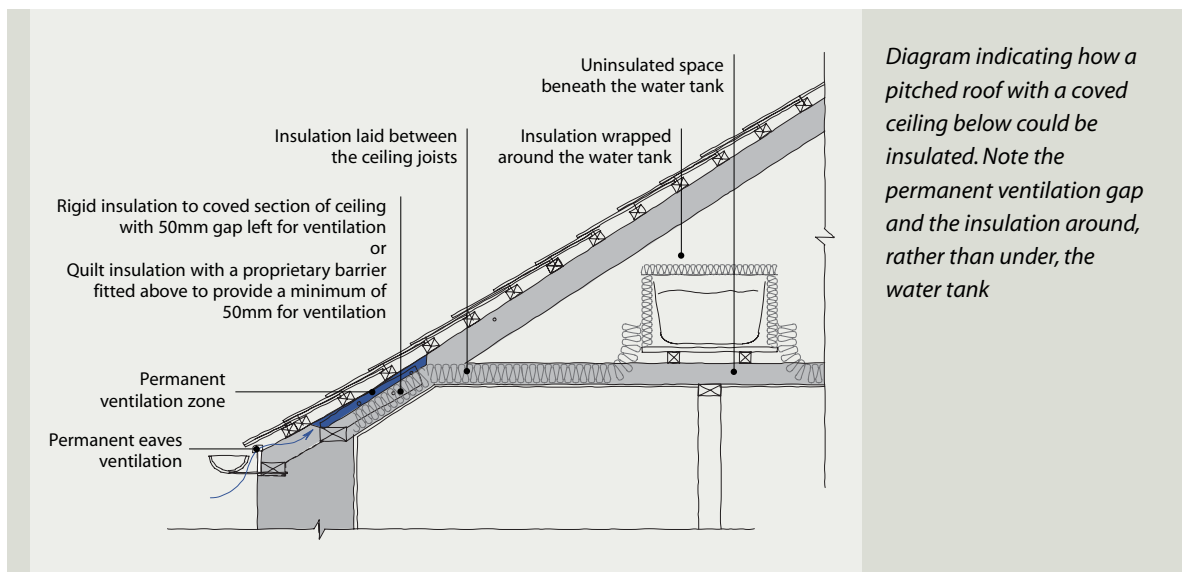

Where a roof is currently ventilated at eaves level, a gap of adequate dimension should be left to allow a continuous 50 mm passageway for air flow. It is common to find covered ceilings with a collar-tie roof structure in older buildings. Where this is the case, it is probably most appropriate to use a rigid form of insulation for the covered section of the roof, allowing a 50 mm ventilation gap over the insulation for the full length of the covered area. The horizontal ceiling joists can then be fitted with any of the insulation products discussed above.

A habitable roof space can be insulated between the rafters. Again, it is essential to ensure that there is continuous ventilation of the roof timbers. In order to achieve this it may be most appropriate to use a high-performance rigid insulation between the rafters.

As a direct consequence of installing insulation at ceiling level, the remainder of the roof above the insulation will be colder. It is therefore important to insulate water tanks and all pipework to prevent freezing. Lower loft temperatures also affect older roofs that have a lime parging between the slates, which serves to secure the slates and impede wind-blown rain. In an uninsulated attic, the parging benefits from the drying effects of the heat coming up from the building below. Following the installation of insulation, both the parging and the slates will be colder, leaving them vulnerable to condensation unless sufficient ventilation is provided in the roof space.



As part of the complete refurbishment of this building, the opportunity was taken to insulate the roof. Rigid insulation has been fitted between the rafters in the sloping sides with quilted insulation fitted between the ceiling joists across the top



A roof with largely intact lime mortar parging applied to the underside of the slates. Parging has an insulation value in itself and helps to reduce air-blown water infiltration

Bats and historic roofs

Bats frequently roost in roof spaces and other parts of buildings. They may be found under the slates, hanging from roofing felt, parging or timbers and in joints and splits in roof timbers. Bats do not pose any significant threat to the fabric of a building nor to the health of its human occupants. Bats are usually only present in the roof space for part of the year but, as they tend to return to the same roosts every year, the roosts are protected whether bats are present or not.

Bats and their roosts are protected by Irish and EU legislation. The Wildlife Acts make it an offence to wilfully damage or destroy the breeding or resting place of a bat. Even where planning permission has been granted or works to a roof are considered exempted development, the requirements of the Wildlife Acts still apply.

When considering any works to a historic roof, the first step is to have a bat survey carried out by an appropriately qualified bat expert. Where bats are present or there is evidence that they have used, or are using a roof, the National Parks and Wildlife Service of the Department of the Environment, Heritage and Local Government should be contacted for informed advice and guidance before any roofing works are programmed and initiated. If there is an active bat roost, works will need to be programmed to cause the minimal amount of disturbance and measures put in place to allow bats to continue to use the roof space upon completion.

The most common and effective method of minimising the impact of roof works on bats is to carry out the work at an appropriate time of the year. The great majority of roosts in buildings are used only seasonally, so there is usually some period when bats are not present. Maternity sites, which are the ones most often found in roof spaces, are generally occupied between May and September, depending on the weather and geographical area, and works should therefore be timed to avoid the summer months.

Larger roofing projects, however, may need to continue through the summer. The best solution in such cases is to complete and secure that part of the roof that is the main roosting area before the bats return to breed. If this is not possible, work should be sufficiently advanced by May or June for returning bats to be dissuaded from breeding in that site for that year. In which case, alternative roosts, appropriate to the species, should be provided in a nearby location. Another possible solution is to divide the roof with a temporary barrier and work on one section at a

time so that the bats always have some undisturbed and secure areas. The advice of a bat expert should always be sought and there may be a requirement for this expert to be present on site during the course of the works.

Where it is proposed to treat roof timbers against fungal or insect attack, careful consideration must be given to ensure that the treatment used will not adversely affect the bats.

Where roofing membranes are to be included as part of roofing works, they should be of a type that allows bats to hang from almost any point. Plastic membranes are mostly unsuitable because bats have difficulty hanging from them, so wind-break netting stretched beneath the membrane should be used.

The completed roof should be accessible and amenable to the returning bats. Access to the roof space can be provided in a variety of ways including the use of purpose-built bat entrances. Bats also need suitable roosting sites and an appropriate temperature regime. This can be provided by the construction of a bat-box within the roof space that has the advantage also of providing some segregation between the bats and building's occupants.

For further information, see the National Parks and Wildlife Service publication *Bat Mitigation Guidelines for Ireland* (2006) which can be downloaded from www.npws.ie.

UPGRADING FLAT ROOFS

The improvement of flat roof insulation is more complex than pitched roof insulation and expert advice should be sought before carrying out alterations, in particular to lead roofs. Flat roof constructions consist of a variety of assemblages of insulation, structure and ventilation layers. Traditional flat roofs are likely to be covered in lead or copper sheet supported on timber boards. It is important to ventilate the underside of metal-sheeted roofs as, if condensation is allowed to form on the underside of lead, it will oxidise, rapidly forming a toxic lead-oxide powder. If oxidation continues unchecked, holes will form in the lead, allowing the roof to leak. As internal access to the structure of flat roofs is often difficult, they are best upgraded when undertaking repair works to replace the roof finish above or the ceiling finish below.

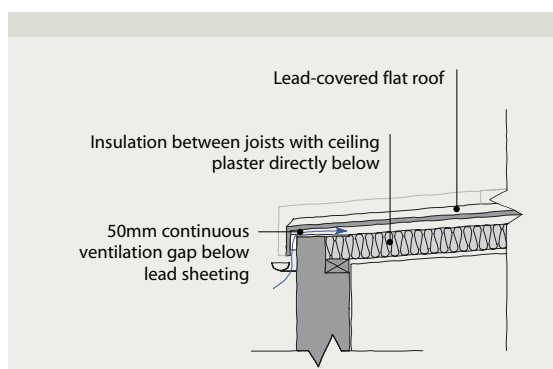

A section through a typical traditional flat roof showing how it might be thermally upgraded. However, installing insulation at this location would only be possible if either the roof covering above or the ceiling below were removed which may not always be in the best interests of conserving the architectural qualities of the building



A recently re-covered lead flat roof. These modern lead roof vents were introduced as, previously, poor ventilation had caused moisture to build up within the roof space leading to timber decay

ISSUES ASSOCIATED WITH INSULATING ROOFS

There are a number of points to be remembered when fitting loft insulation. First, before any insulation works take place, the roof timbers should be inspected for fungal or insect attack. Treatment for furniture beetle, or woodworm, may include coating timbers with an insecticide, although it is also possible to control infestation by using adhesive flypaper to catch the adult borer on the wing. Treatment for fungal infestation normally involves treatment with a fungicide. For further information, see *Roofs – a guide to the repair of historic roofs* in this Advice Series.

It is important that roof spaces are insulated thoroughly and consistently. A partially insulated roof may result in problems with condensation within the roof space or mould growth on ceilings below uninsulated areas due to thermal bridging.

Care should be taken with regard to electrical cabling, particularly older installations within roof spaces. In general, insulation should be fitted beneath electric cables to prevent them from overheating which could create a fire hazard.

The underside of the water tank should never be insulated as heat rising from the rooms below provides some heat to the tank, preventing the water in the tank from freezing. Instead, the exterior of the tank and the associated pipework should be wrapped in insulation and overlapped with the remainder of the ceiling insulation.

All insulating materials placed above the ceiling will conceal the structural elements from view and also from inspection. Future access requirements to roof timbers should therefore be borne in mind when choosing an insulation product.

Walls

In considering how or if the thermal insulation of traditional walls can be improved, it is important to fully understand how the existing walls were constructed, how they were designed to deal with the Irish climate and the significance of historic finishes to both the exterior and interior.

Because of the importance of breathability in traditionally built buildings, any material being applied to the walls should be vapour-permeable, that is, should not encourage or allow water or condensation to accumulate within the fabric of the wall. Walls often have timbers embedded in them and high levels of moisture, from whatever source, could create conditions that promote fungal decay or insect attack of timbers.

As traditional walls are generally of solid masonry, thermal upgrading can usually only be considered in two ways: lining the interior of the wall or applying a new face to the exterior of the wall. Either of these actions can have a significant effect on both the character and the physical well-being of a historic building and, in the context of a protected structure or

an architectural conservation area, generally require planning permission and may not be considered appropriate.

Traditionally built masonry walls in Ireland were generally constructed of varying combinations of stone, brick and lime-based mortar, of solid construction, sometimes with a core of lime mortar and rubble filling. These materials are porous, allowing moisture to be absorbed by the wall and later released, depending on the weather conditions. They are soft and flexible and can accommodate small amounts of movement within the fabric. Modifications to traditional walls should ensure that the breathability and flexibility of the structure are maintained.

Wall finishes are an important element in the quality and character of traditional buildings and may include exterior finishes such as cut stone, rubble walls with dressed openings, brick, or lime render. Internally, there may be timber panelling, lath-and-plaster or lime plaster finishes, at times with decorative plasterwork embellishments such as cornices.

Wall type	Internal finish	Thickness	U-value
Locharbriggs sandstone	Plastered on the hard	550 mm	1.4 W/m ² K
Locharbriggs sandstone	Lath and plaster	550 mm	1.1 W/m ² K
Locharbriggs sandstone	Plasterboard	550 mm	0.9 W/m ² K
Brick	Plastered on the hard	400 mm	1.1 W/m ² K
Craigleith sandstone	Plastered on the hard	600 mm	1.5 W/m ² K
Craigleith sandstone	Plastered on the hard	300 mm	2.3 W/m ² K
Craigleith sandstone	Lath and plaster	600 mm	1.4 W/m ² K
Craigleith sandstone	Plasterboard	600 mm	0.9 W/m ² K
Kemnay granite	Plastered on the hard	350 mm	1.7 W/m ² K
Kemnay granite	Lath and plaster	600 mm	0.8 W/m ² K
Kemnay granite	Plasterboard	600 mm	0.9 W/m ² K
Red sandstone	Plastered on the hard	400 mm	1.3 W/m ² K
Blond sandstone	Lath and plaster	600 mm	0.9 W/m ² K

Recent research has found that the U-values of traditionally built walls are more favourable than previously acknowledged. The research identified U-values for differing construction compositions and widths. The results for walls of varying thickness, with plaster applied directly onto the wall, range from 1.1 – 2.4W/m²K. Correlation was found between the thickness of the wall and the U-value results (Source: Paul Baker 'In Situ U-Value Measurements in Traditional Buildings – preliminary results')



The wealth of architectural detail and the quality and craftsmanship of materials used in historic buildings make them unsuitable candidates for external insulation. Even where the exterior of a traditional building is relatively plain, the alteration of the character and the need to replace window sills, remodel eaves details and the like would make the installation of external insulation inappropriate in many cases

REDUCING LEVELS OF DAMP IN WALLS

Before considering upgrading, it is important to ensure that the wall is in good condition, that pointing is intact or rendering in good order and that obvious sources of damp such as leaking gutters and rainwater pipes are repaired. Additionally, the risk of rising damp can be reduced by ensuring that the external ground level is not higher than the internal floor level or by installing a French drain externally to improve the condition of the wall. In certain cases, injecting a damp-proof course (DPC) may be considered. While it is normal practice for modern buildings to incorporate

an impervious damp-proof course to prevent moisture from the ground rising up through the walls, most historic buildings were constructed without a DPC. Installing a DPC in a building which did not originally contain one can be problematic. Expert analysis of the problem should be carried out before undertaking any works of this kind and it is essential to ensure that the cause of dampness has been correctly diagnosed before any drastic or invasive works are considered. For further information see *Maintenance – a guide to the care of older buildings* in this Advice Series.



Where there are persistent problems with damp, it is important to ensure that the external ground level is lower than the internal floor level and, if necessary, consider installing a French drain below ground level with a gravel finish. Water percolates through the gravel finish to a perforated drain below, following which it drains to a soakaway at a distance from the building. The rendered wall finish will generally require repair following the lowering of the ground level. The installation of a French drain around buildings in sites of archaeological potential, such as churchyards, will require careful prior assessment and consultation with the relevant authorities

EXTERNAL INSULATION OF WALLS

In order to fully exploit the benefits of its thermal mass, a solid masonry wall would ideally be insulated on the exterior face. At a basic level, low-density renders such as lime-based renders achieve this. Insulation materials which are moisture resistant are used in combination with special renders to achieve higher levels of insulation. However, as many external façades would be completely altered by the addition of external insulation, it is likely to be inappropriate for most traditional buildings. Even on buildings with plain rendered façades, external insulation is problematic as the thickness of the insulation affects details at all junctions around windows and sills, eaves and gutters, doorways and any items fixed to the walls, at junctions where the building meets the ground and with neighbouring houses in terraced and semi-detached buildings.

External insulation has certain advantages over internal insulation: the benefits of the high thermal mass of a solid masonry wall are retained; there is a reduced risk of condensation between the insulation layer and the masonry wall; the building fabric remains dry and heated from the interior and there is no impact on internal finishes and room sizes. Among the drawbacks is the fact that the materials are relatively untried and untested in Irish climatic conditions.

Random rubble stone walls of habitable buildings would originally have been rendered externally. In some cases, the original render has been mistakenly stripped off to reveal the rubble stonework making it vulnerable to moisture ingress and potentially reducing its thermal efficiency. The re-rendering of external rubble walls using a render of an appropriate specification slows down the loss of heat from the interior; improves the warmth of the masonry wall; provides essential protection against the elements and a barrier to the passage of moisture.



A lime-rendered façade, in good condition, improves the insulating value of a wall and prevents damp penetration to the inside of the building

With very careful consideration and specialist professional advice, there is some potential to upgrade random rubble stone walls of ruinous buildings or buildings which have already undergone significant alterations such as removal of external plaster and replacement of sills. Intact historic render should not be removed. Any materials used should be as breathable as the existing walls. Proposals to insulate the exterior of a protected structure or a building within an architectural conservation area will almost certainly require planning permission. Prior to carrying out works, it is advisable to consult with the architectural conservation officer in the local authority. However, even where a building is not a protected structure nor located within an architectural conservation area, planning permission will be required where the works would materially affect the external appearance of the structure so as to make the appearance inconsistent with the character of the structure or of neighbouring structures.

Mud walling is a relatively fragile method of construction; being highly susceptible to changes in humidity, too much drying or wetting can result in failure of the wall. It is not advisable to undertake works to insulate such walls either internally or externally.

INTERNAL INSULATION OF WALLS

The upgrading of the interior of existing walls will alter an internal room to varying degrees depending on the level of finish. It can be very intrusive and is rarely appropriate for traditional buildings with interiors of architectural significance.

Traditionally, walls in Ireland were plastered internally straight onto the masonry ('on the hard'). Any addition of insulation will add to the wall depth, reducing the size of the room, interfering with the historic finishes and requiring the relocation of all electrical points and switches, wall lights and radiators. An increase in wall depth will adversely affect all decorative finishes such as plasterwork cornices, architraves, shutters and skirtings. If the building is a protected structure, such works are unlikely to be acceptable. Even where the building does not enjoy legal protection, the loss of such fine architectural features may not be acceptable to an owner. A plain room with no cornice and minimal joinery may be easier to insulate but requires careful consideration in relation to maintaining the breathability of the building fabric.

Where they exist, timber stud and lath-and-plaster lined external walls may provide thermal upgrading opportunities. This type of wall construction is relatively unusual in Ireland. Where walls are constructed in this manner and the lath-and-plaster has deteriorated and requires replacement, there may be scope for insulating behind the lath-and-plaster without increasing the depth of the wall. Intact lath-and-plaster should not be disturbed.

As well as the aesthetic and architectural conservation considerations, there are other potential difficulties in lining the interior of existing walls. Unlined masonry walls benefit from interior heat that keeps them dry. When the walls are lined, moisture ingress from the exterior and low external temperatures may result in a problematic build-up of moisture within the original building fabric. There is also a possibility that condensation may occur between the insulation and the wall fabric, resulting in further moisture build up. In order for moisture in the walls to dry out, any new lining should be as breathable as the wall itself; even inappropriate paints can affect the breathability of the wall. The addition of insulation to the interior also alters the ability of the building to moderate temperature through its thermal mass. If an interior is to be thermally upgraded the insulation should be applied to every surface, including small areas like window reveals and the junctions between ceilings and floors above, to



Lining the internal walls of a building will often not be acceptable, particularly if the walls are finely decorated as in this Georgian room

avoid any possibility of thermal bridging which could result in mould growth. This may be hard to achieve, expensive, and extremely disruptive to the historic interior and is unlikely to be permitted in a protected structure.

Consideration could be given to insulating parts of walls such as recessed areas beneath windows where the wall depth is thinner and therefore likely to be losing more heat. It should generally be possible to upgrade these types of areas locally without any interference with the rest of the room. Window openings, for example, were often lined with panelled joinery; the panel below the window could be carefully removed, fitted with an appropriate depth of insulation and the panel re-instated. This process is described in further detail in the following section on upgrading windows.

As interior works to a protected structure or a proposed protected structure may require planning permission, the architectural conservation officer in the local authority should be consulted regarding any proposal to carry out insulation upgrading works.

Windows, doors and rooflights

Traditional windows are an intrinsic part of the character of our historic and vernacular buildings. In Ireland, most surviving traditional windows are timber-framed, vertically sliding sash windows with single glazing. Other traditional windows include casements or fixed lights of timber or cast iron, leaded lights and twentieth-century metal framed windows. The quality of the timber and workmanship found in older windows is generally far superior to that found in modern ones and, when properly repaired and maintained, traditional windows will commonly outlast modern replacements. For further information, see *Windows: a guide to the repair of historic windows* in this Advice Series.

Between 10-15% of the heat lost from a building can be through its windows, by a combination of radiant heat loss through the glass, conductive heat loss through the glass and frame and ventilation heat loss through gaps in the window construction. This is low compared with the estimated average 25% heat loss through the roof and 35% through external walls. Yet windows are most often the first target of energy efficiency works.

In terms of heat retention within a building, older windows may appear to perform poorly when compared to some modern windows. It is, however, possible to repair and upgrade traditional windows to bring them up to a similar, if not higher, standard than modern double-glazed windows and to improve the



Terraced houses with replacement uPVC-framed windows. These windows are unsympathetic to the character of the houses; opening outward instead of sliding up and down, they disrupt the streetscape; the modern glass creates jarring reflections; while the thick frames contrast poorly with the elegant timber sections of the original sash windows

comfort of occupants without damaging the character of the building. Prior to considering works, the actual heat loss through the windows should be considered. In buildings where windows are small compared to the overall wall area, upgrading the windows may not result in a significant improvement in comfort levels or in energy savings.

When considering the replacement of windows, a number of factors should be taken into consideration. First and foremost is the potential effect on the character of the building and the architectural heritage value of the existing windows. Also to be considered are the financial cost, the energy required to produce a new window, its embodied energy, and the environmental cost related to disposal of waste. Modern double-glazed window units are expensive and high in embodied energy. The initial financial cost and embodied energy consumption may never be recouped by cost and energy savings on heating bills within the serviceable life of such windows. Instead, simple upgrading of existing historic windows can eliminate draughts and reduce heat loss. This costs less and is kinder to the environment than fitting new replacement windows.

The use of uPVC in traditional buildings should generally be avoided. uPVC is a material with very high embodied energy which has a short lifespan as it is difficult, if not impossible, to repair. Simple wear-and-tear often results in whole units requiring replacement after relatively short periods of time. The manufacture of uPVC also results in many toxic and environmentally damaging by-products. In addition, uPVC is generally



A pair of houses with well-maintained timber sliding sash windows

not recycled or compressed and must be disposed of in landfill sites as the burning of uPVC can result in the emission of toxic fumes.

The installation of uPVC windows in a protected structure or within an architectural conservation area is generally not considered acceptable as such windows would be inconsistent with the character of historic buildings.

DRAUGHT PROOFING OF WINDOWS

Draughts may result in heat loss and are also uncomfortable, resulting in a perception that a room is cooler than it actually is. Draught proofing of a window will not improve its U-value but stopping draughts will reduce heat loss and improve the thermal comfort of the occupants. The overall aim should be to gain control of the rate of ventilation in the room concerned.

The first step in reducing draughts is to overhaul the windows by carrying out any necessary repairs and ensuring that the sashes or opening lights operate properly within the frame. A window that is in good working order can be fitted with draught-proofing strips. However, with some particular old, delicate or valuable window frames, cutting grooves to insert draught proofing will not be appropriate and expert advice should be sought on alternative methods of upgrading.

Typically gaps up to 6 mm can be filled with any one of a variety of available strips including nylon brushes, pile (dense fibre), polypropylene with foam filler and silicone rubber tubes. The fitting of strips varies with



A repaired window frame with a replaced style and new parting bead. The timber sash frames have been temporarily removed

some fixed to the surface of the frame and others fitted into the frame by cutting grooves into it. When fitting a product that requires grooves in the frame care should be taken to ensure that the joints are not damaged in cutting the grooves: these are best fitted by a specialist joiner. Care should also be taken to ensure that existing ironmongery such as handles, catches and hinges will continue to function correctly following draught-stripping and that the colour of the product is appropriate to the window. Dimensions of draught strips should be appropriate to the gap to be filled as larger strips will put pressure on the window itself and smaller ones will not adequately seal the gap. Strips should have some flexibility in them to ensure they will work with the expansion and contraction of timber between summer and winter months. Metal and timber casement windows can be upgraded with similar type draught strips. Casement windows can also have mastic sealants applied to form a moulded profile when the opening section is closed over the mastic to shape the sealant to the gap. Care should be taken to use a barrier to prevent the opening window from sticking to the silicone and the window frame when fitting the seal.



Draught-proofed window frame: brushes are visible on the staff and parting beads, both of which have had to be replaced in order to draught proof. For the brushes to work properly it is important that they are not painted over

There is a wide range of quality in available draught-proofing products and assurances should be sought as to the lifespan of a product prior to fitting. In addition, it is important that the product can be removed easily without causing damage to the historic window frame to ensure that when it reaches the end of its life it can be replaced. It should also be noted that flexible draught-proofing strips such as brushes and rubber will cease to operate correctly if painted as part of redecoration works.

As discussed in the section on ventilation above, windows in rooms with no alternative means of ventilation such as wall vents or open flues should never be fully draught proofed.

DRAUGHT PROOFING OF EXTERNAL DOORS

External doors in an older building may have become ill-fitting over the years and so are often poor at keeping in heat. Traditional doors can be draught proofed in the same way as windows with various draught-proofing strips widely available. The bottom



Aluminium draught strips can be seen to all sides of this door. The metal part of these strips, unfortunately visible, can be painted (although it is difficult to achieve successfully) but it is important that the flexible sealant strip is not

of external doors can also be fitted with a weatherboard providing this can be achieved without damage to a historic door. Letterbox brushes or flaps can be fitted to reduce draughts. For historically important buildings, discreet draught proofing should be used. In some buildings it may be possible to provide a draught lobby to the interior of the external doors. For a draught lobby to be successful there must be adequate space to close the external door prior to opening the internal door. Installing a draught lobby in a protected structure may require planning permission and the architectural conservation officer in the local authority should be consulted when considering works.

IMPROVING HEAT TRANSFER

A single sheet of glass will transfer heat quicker than a double-glazed unit. People feel colder sitting close to single-glazed windows as they lose heat by radiation to the cold inner surface of the glass. Tall windows can result in what is known as 'cold dumping', where the temperature of the air next to window is considerably colder than the rest of the room, as the cold air is denser and heavier it falls, or dumps. This is one of the primary reasons for placing radiators below windows. There are simple solutions to keeping heat in a room with single glazing that are more effective than fitting double-glazed units and more appropriate for use in a historic building and several of these are discussed below.

EXISTING SHUTTERS AND CURTAINS

Many Georgian and Victorian buildings were originally constructed with internal timber shutters to the windows. During the Edwardian period, shutters began to fall out of fashion and were supplanted by heavy curtains. The best way to reduce heat loss in the evenings and at night is to use such shutters. If they are no longer operational they should be repaired and put back in working order. Blinds or heavy curtains, which could include an insulated inter-lining, when used with the shutters will further improve heat retention; there are specially designed thermal blinds available which can improve on this again. There may be some scope for upgrading shutters using a thermal lining applied to the rear of the shutter panels; for the shutters to continue working it is important that the overall thickness of the shutter is not increased. The feasibility of upgrading will depend on the available depth between the shutter panel and shutter frame.

It is likely that the available space will only allow for a lining depth of approximately 5 to 10 mm. High-performance, super-insulating linings should be considered for thin spaces of this type.

Where the original timber window shutters have previously been removed from a building, or from parts of a building, consideration should be given to reinstalling shutters of an appropriate design accurately based on evidence, for example, from shutters on an adjoining contemporary building or from evidence within the building itself.

The window aprons (the area of wall between the window sill and the floor) can be an area of increased heat loss as the wall thickness was often reduced at windows to provide a recessed opening. Where the window apron is timber panelled, the panels can be carefully removed and the void behind filled with insulation. The depth of insulation possible will depend on the available space between the timber

panelling and the external wall. A specialist joiner should be consulted and appointed to undertake works to the shutters and window apron.

The shutter box, into which the shutters fold when not in use, is often a source of draughts that is overlooked. To reduce or eliminate air movement in and around the edge of the shutter box, the exterior should be pointed up with an appropriate material which remains flexible following hardening and provides a long-lasting unobtrusive seal between the window frame and surrounding masonry. From the inside, the junction of the interior of the shutter box and the wall should be caulked with environmentally friendly hemp/lime products or other suitable materials. When sealing the interior of the shutter box, it is important to ensure that the caulking does not interfere with the operation of the sash weights or the shutters, such as may occur if using expanding foam, which is not easily controlled.



Working timber shutters: the interior of the shutter boxes could be lined and sealed to reduce air leakage. Any new linings should not prevent the shutters from folding back into the shutter box when not in use



A well-sealed shutter lining

SECONDARY GLAZING

For buildings that are primarily used during the day it may be appropriate to consider secondary glazing. Secondary glazing is a full-sized window panel fitted directly inside the existing window, which acts in a similar way to double glazing. It can be temporary or permanent and should be fitted to slide or open inwards in such a way as to allow for easy opening of the original windows for ventilation purposes, cleaning and emergency escape. The style and manner in which the unit opens should be visually appropriate for the window to which it is being fitted and easy for the end-user to operate. Any division in the panel should be located to match the frame of the existing window, such as at the meeting rail of a sash window. Duplication of individual panels looks unsightly from the exterior and should be avoided. Secondary glazing should be sealed to the interior but the original windows should be ventilated to the exterior to prevent condensation forming between the two windows, which is not only unsightly but is potentially damaging to the historic building fabric. Therefore, if secondary glazing is to be fitted, the original windows should not also be draught proofed.

While secondary glazing is effective it is only appropriate if it does not affect the character of the windows and room in which it is fitted. Formal rooms or rooms with high quality decorative finishes may be compromised by the fitting of secondary glazing. The use of the room is also important. If rooms are plain and used as, for example, offices or kitchens, the fitting of secondary glazing may be appropriate. If rooms are not often used during the day it would be more appropriate to leave the windows as they are and use any existing shutters.

Secondary glazing should always be fitted in such a way that it is still possible to use existing shutters. Slim-line secondary glazing is available which can be fitted in place of the staff bead between the bottom sash and the shutters. This allows the shutters and curtains to be used at night when outside temperatures are lower. The combination of secondary glazing, shutters and curtains has the potential to match the insulation properties of triple-glazed windows. Secondary glazing alone can result in better overall thermal performance than a standard double-glazed window. The fitting of secondary glazing should be reversible and carried out with minimal interference to the existing window, shutters and



Inappropriate timber-framed secondary glazing with frame proportions that do not match those of the original window, creating a discordant appearance

linings. The fitting of secondary glazing in windows which retain no historic linings to the interior allows for more flexibility in the type and size of secondary glazing frame which may be fitted.

Secondary glazing has the added advantage that it can be removed and safely stored during warmer months to maximise solar gain (the heat gained from the sun through the windows). When sunlight passes through a pane of glass, its light and heat are absorbed or reflected; the greater the number of panes of glass the smaller the amount of heat and light passing to the interior of the room. It is therefore advantageous to be able to remove the secondary glazing during the summer and benefit from the maximum light and heat from the sun. During the winter, when the sun is not as hot, the amount of heat lost from the interior, if not secondary glazed, will outweigh the amount of heat to be gained from the sun. Secondary glazing has an additional benefit in that it reduces the amount of noise which passes through a window.



An Edwardian window with 1950s secondary glazing. The secondary glazing is chunky and does not match the original window profile and blocks light from the room. The position of the frame within the opening prevents the shutters from being used



Carefully designed bespoke secondary glazing installed as part of Changeworks' Energy Heritage project (Image © Changeworks)

DOUBLE GLAZING

Original or early-replacement windows in a traditional building should generally not be replaced with double-glazed windows. Replacing windows in a protected structure requires planning permission and this is unlikely to be granted as double glazing will rarely be in keeping with the character of traditional buildings; modern double-glazed windows are made with chunky sections of framing which are necessary to hold the double-glazed units in place. These proportions are very different to those of traditional windows which are generally made of fine timber sections.

The fitting of double-glazed units into existing timber frames is rarely appropriate or achievable; in order for the glazing units to be effective at reducing heat-loss the gap between the glass panes in the unit should be a minimum of 12 mm, resulting in a total unit depth of approximately 20 mm including the two pieces of glass. Historic sash frames are generally finely crafted

from slim sections of timber, the depth and strength of which would not be adequate to support double-glazed units. The existing windows would be both visually and physically compromised as a result. In addition the aesthetic appearance of the black or silver edging to the double-glazed units is unsightly.

Double-glazing technology is constantly improving and research is currently being undertaken to reduce the depth of double-glazed units, while maintaining effective U-values. The use of slim-line double-glazed units may be appropriate in situations where one-over-one pane sash windows require replacement but not where the existing historic glass survives or where the new units would be too heavy for the historic window frames. As with all double-glazed units, the cost of these high-tech components is unlikely ever to be recouped over their lifespan, while the gases used to fill the cavity can have a high embodied energy.

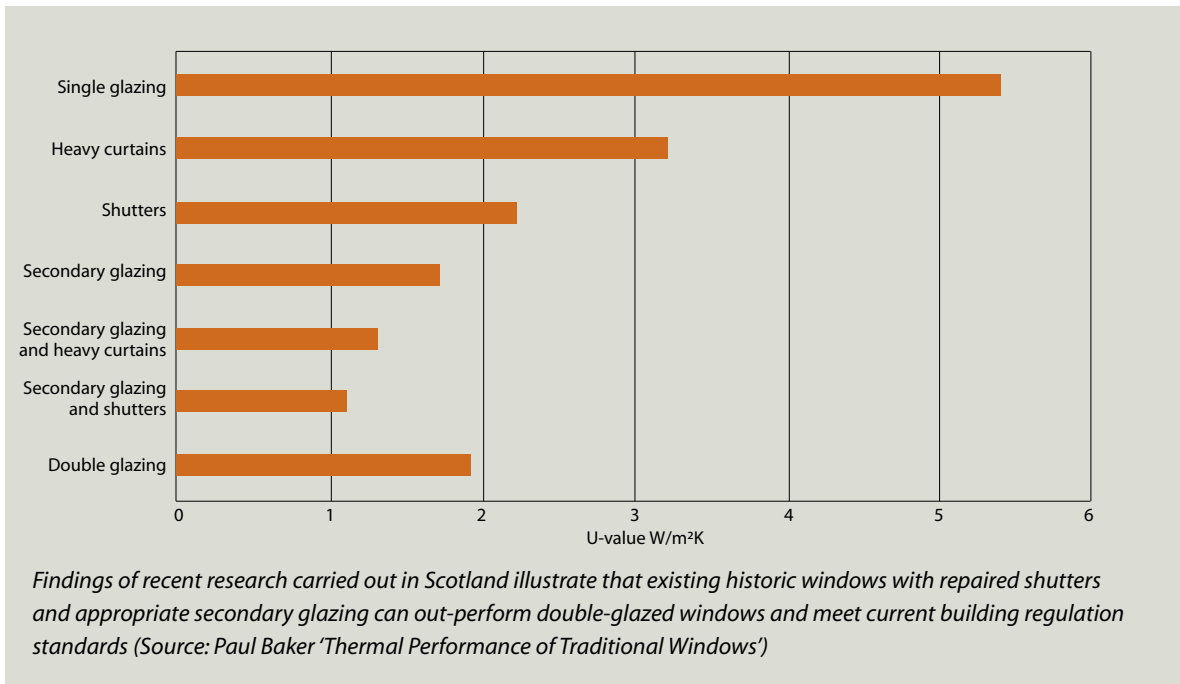

UPGRADING OF TRADITIONAL ROOFLIGHTS AND SKYLIGHTS

Upgrading traditional rooflights generally involves some loss of historic character. Older rooflights should be maintained in good working order. If a rooflight has reached the end of its working life it may be replaced with a modern rooflight that matches the existing, probably timber or steel, with similar profiles. As rooflights differ from windows in detailing and design, it will often be possible to incorporate a double-glazed unit. New, small double-glazed rooflights are available off the shelf. Light shafts leading to a rooflight should be insulated in the course of providing roof insulation.



Historic skylights and lanterns, such as this fine example, should be well-maintained but are rarely suitable for thermal upgrading



This modern double-glazed skylight allows access to a concealed valley gutter for maintenance inspections and cannot be seen from ground level. It also lets additional natural light into the attic space below

Floors

The ground or lowest floor in a building is the most important floor to consider for effective thermal upgrading, unless it is an unheated space, such as a cellar, in which case the floor above should be insulated. An estimated 15% of the heat within a traditional building is lost through its ground floor. In such buildings, lower floors are of varying construction types and have different finishes. Both ventilated and unventilated suspended timber floors are particularly common at ground floor level. Stone flags, tiles or brick paving laid on solid floors (often bare earth) are also common, particularly within basements. In a public building or church, a range of floor types is found, often for example, with a stone or tiled finish in the circulation spaces, typically with an unventilated timber floor beneath the pews or seating areas.

Improving the thermal performance of the ground floor reduces the overall heat loss from a building, and can also significantly improve comfort levels by providing a warm floor underfoot. In a historically important building it may, however, be difficult to upgrade a floor without loss or disturbance of significant finishes such as tiles or brick paving and therefore particular care needs to be taken when considering insulation works to such floors. Planning permission may be required when lifting such floors to allow for insertion of insulation. In some cases, because of the potential for damage to important finishes, such works may be considered inappropriate.



Decorative and high quality floors are difficult to upgrade and require careful analysis of the time, cost and, above all, the potential damage that could be caused to the historic finish in exchange for improved thermal performance. Fine floor finishes such as these tiles should not be lifted

SUSPENDED TIMBER FLOORS

Suspended timber floors were constructed in the past both as ventilated floors with vent bricks or grilles in the exterior walls and as unventilated floors. By the nineteenth century the latter were less common. Where vents are provided it is important to ensure that these remain unobstructed as they ensure that any moisture which may reach the floor timbers can escape, preventing a potentially damaging build-up of moisture levels in the space beneath the floor. If a floor is not ventilated it may be appropriate to consider providing vents subject to consideration of the effect on the visual appearance of the façade. If any vents have been blocked up in the past, it is important to reopen them. Vents should not be regarded as the cause of unwanted draughts as they are an essential part of the proper functioning of the building and vital to maintaining it in sound condition. Floor coverings such as rugs or carpets will eliminate draughts and the underside of the floor can be upgraded with insulation.



A floor vent to ventilate the ground floor was built into the wall between the cellar and ground floor windows as part of the original design

If there is a crawl-space beneath the floor it is usually easier to upgrade suspended timber floors from below as the joists and floorboards are generally exposed from the underside. However, if access beneath the floor is not possible then the floors should be upgraded from above by lifting the floorboards. Great care should be taken when lifting old floor boards, especially the wide boards found in many Georgian houses; if any are damaged or broken it will be very difficult to find matching boards for repairs. The fixings used for old floor boards can themselves be of interest and can be damaged or lost through careless lifting methods; strips of metal or timber dowels, were often used in high quality work to fix boards to each other.

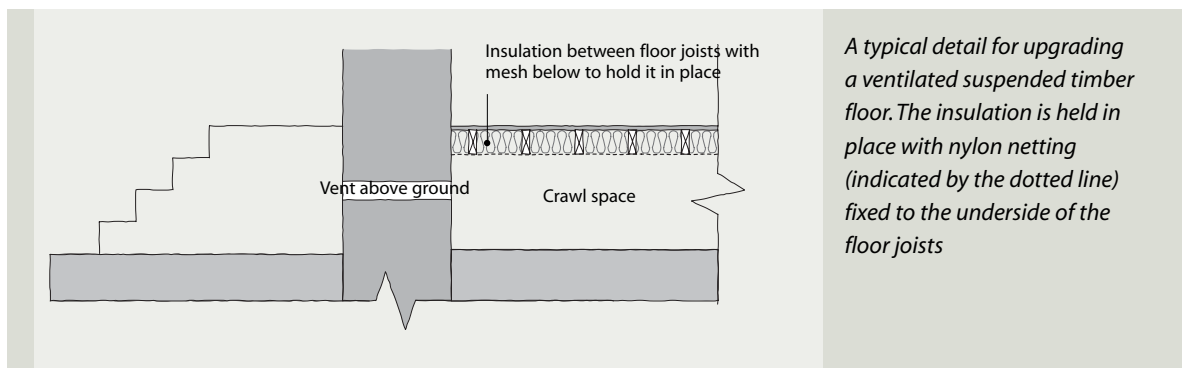

Alternatively, floor boards may be tongued-and-grooved together which makes lifting individual boards difficult to achieve without damage. If working from below, quilted insulation such as sheep's wool, hemp, rockwool or cellulose fibre can be fitted for the full width and depth of the joists and held in place with nylon netting stapled to the joists. If working from above chicken wire or plastic netting can be moulded around the joists to form trays between them which are then packed with quilt insulation before the floor boards are refitted. An alternative method of fixing from above is to fix battens to the sides of the joists and fit rigid insulation between them. Note that it can be difficult to cut the insulation to fit perfectly and any resulting gaps will compromise its insulating performance.

SOLID FLOORS

The easiest way to upgrade an existing solid floor is to add a layer of insulating material above it with a new floor finish on top. The covering of an existing floor should only be considered if it is of no architectural or historical interest. Floor finishes such as decorative tiles, brick, wood block or stone flags should not be covered over although in some cases it may be possible to carefully lift these to allow for re-laying over the new, insulated floor. Floors which have previously been interfered with and have modern finishes such as concrete are the most appropriate candidates for covering with insulation. However, this will increase the height of the finished floor level and affect internal features such as skirting boards, window linings, doors and architraves and cause difficulty at the foot of stairs. Such alterations, in their own right, can be inappropriate in some interiors and will need to be considered on a case-by-case basis. The laying of a new insulated floor over an existing floor may also reduce the height of the space. Such modifications to the interior of a protected structure are likely to require planning permission and the planning authority should be consulted before any works are undertaken.

Basement floors are usually solid. The use of the basement should be considered prior to upgrading the floor and if it is used for activities not requiring heat it may be appropriate to insulate above the basement level instead. Expectations for a warm, insulated, dry basement may not always be realisable in older buildings.

If a building is undergoing restoration or major refurbishment, the opportunity may be taken to lift or excavate the existing floor and to lay insulation on a new subfloor. However, this option should be carefully considered for a number of reasons. The excavation of an existing floor and the laying of a new floor slab can in some cases undermine walls which have very shallow, or indeed sometimes no, foundations or footings. Vibrations arising from the works can also potentially cause structural damage. Care should be taken in buildings built over a high water table or with pre-existing problems with rising damp. It is possible that, as a new sub-floor will seal the floor, moisture which previously evaporated through the floor joints will now be trapped and may be forced to make its way over to the walls, thus increasing the risk of damage to fabric from rising damp. If it is decided to lift a floor for the purposes of adding insulation, it may be worth considering the installation of underfloor heating as part of this process. Underfloor heating is most effective when laid in solid floors with a hard floor finish such as stone or tiles. Traditional buildings may benefit from the low levels of consistent heating provided by underfloor heating at ground level as it will help keep the bottom of walls dry.

There is considerable interest in the use of vapour-permeable flooring construction, using concretes made of lime with hemp or expanded clay. These materials may be appropriate where there is a delicate moisture equilibrium to be maintained. Circumstances which require a radon barrier would make the case for using such materials less compelling. Building Regulations also imply that new floors should be impermeable.

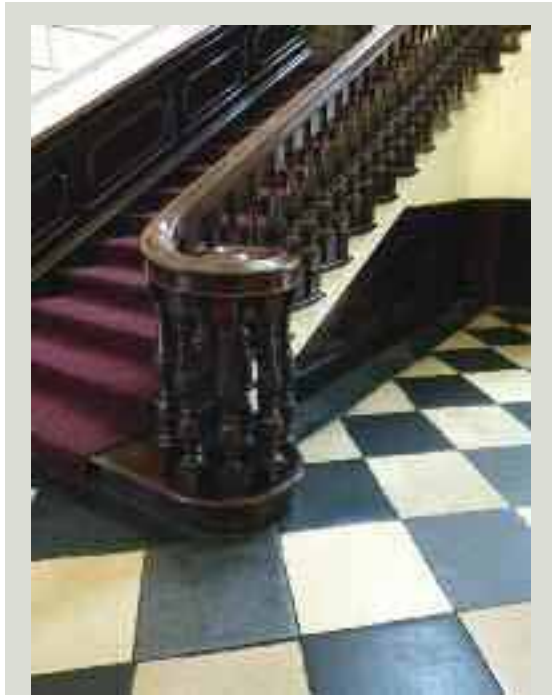

Solid stone floor: upgrading a stone-flagged floor such as this would inevitably result in an unacceptable level of damage or breakage of individual flagstones and should be avoided

Services

As the opportunities to increase insulation in a traditional building are relatively limited, building services and their controls can play a large part in improving energy efficiency. In most traditional buildings, building services such as heating systems, plumbing and electrical installations are not original to the building and there may therefore be some flexibility in altering them.

Heating systems, plumbing systems and electrical installations normally have a shorter life than their host building; electrical installations are typically renewed every twenty-five years, piped services less frequently. There is scope when renewing such installations to significantly improve the energy efficiency of a traditional building, always bearing in mind that intrusive works to protected structures require careful consideration and should only take place after professional conservation consultation, advice and detailed design which take fully into account the value of the existing fabric.

The properties of historic buildings (high thermal mass and slower response time), together with issues related to the installation of services mean that systems which are not usually considered for use in modern buildings can be most appropriate in historic buildings.

Solutions are not always as simple as they may seem and a holistic approach should be taken to looking at the benefits as well as the future consequences of any given system. Also, technology in this area is constantly evolving and new products are regularly becoming available. The efficiencies of differing heating systems that are used in Ireland can be found on SEAI's Home-heating Appliance Register of Performance (HARP) database.

WATER CONSERVATION

Many historic buildings, particularly those in isolated rural locations, had systems for collecting and storing rainwater. Where old collection systems survive, such as lead or copper tanks in the upper reaches of buildings, water butts or water barrels, it may be possible to bring them back into use as a water conservation measure and for use in activities such as watering the garden or washing cars. Overflow systems, safety systems and protection against flooding should be put in place and maintained.

Any proposal to use collected grey water (waste water from such domestic activities as clothes-washing, dish-washing and bathing) for use within the building or for use in appliances should be based on expert advice.

Water supply and drainage services increase the risk of damage when used on upper floors, plaster ceilings being most at risk. The greatest risk is from a burst pipe in the roof space, usually caused by an uninsulated pipe freezing during the winter months. To prevent this, all water services pipes outside of the insulated envelope of a building should be lagged.

PLUMBED HEATING SYSTEMS

As discussed elsewhere in this booklet, designers of older buildings were sometimes surprisingly sophisticated in understanding buildings, their ventilation and heating. While innovations in services tended to be applied to institutional buildings, elsewhere there is evidence of successful technologies, such as the use of cast-iron radiators. Heavy cast-iron radiators, emblematic of nineteenth-century applied technology, were an important invention, durable and efficient. Their moderately slow

response time is particularly suited to avoiding thermal shock, that is, an abrupt change in temperature, in older buildings. Churches, in particular, often retain components of nineteenth-century heating systems, where large pipes carrying hot water were laid in trenches covered with open cast-iron grilles, or arranged at low level around walls or between pews. These systems work on the principle that hot water rises, so that a boiler was located at basement level and the hot water circulated under its own thermodynamic impulse through the pipes, heating the spaces it passed through.



Hot-water heating pipes in a typical nineteenth-century floor duct

Ferrous metals in contact with water are prone to rust and so such systems have tended to deteriorate. Historic cast-iron radiators may sometimes be in sufficiently good condition to warrant reuse. However, a careful evaluation of the risk of leaking or flooding should be made. While modern hot-water-based central heating systems employ pumps and contain a comparatively small amount of water, there is no technical reason not to employ sound old radiators, and indeed the advantage of the thermal mass of the cast iron and the moderate heating up and cooling down time associated with them means that they are good to use in historic properties.

When pipework was retrofitted into buildings, the pipes were often ill-fitting, leaving gaps for draughts. Equally, when such pipes were removed in the past, the resultant holes were not always fully closed up. These holes may admit water, air or even smoke in the event of a fire and should be properly sealed up.

Older buildings were originally heated with open fires but it is likely that this form of heating is now superseded in many houses. Open fires are very inefficient with only 30% of the heat being emitted into the room. In most buildings open fires will be



Existing holes in floors or notches in joists can be reused to accommodate new runs of services. New holes or notches should not be created to avoid further weakening of the joists which has occurred in this example. Where there is existing pugging within the floor space, it should preferably be left in place



New and redundant holes in floors should be made good, fire-sealed where appropriate, and finished to match the existing floor. Where new service runs would interfere with the fabric of a protected structure, planning permission may be required

supplemented or have been replaced by a central heating system fuelled by oil, gas or timber fired boilers. While boilers are more efficient than open fires, typically operating at approximately 70% efficiency, significant improvements in efficiency have been made in recent years with 95% efficiency boilers now available. This means that 95% of the energy in the fuel is converted to heat resulting in less fuel being burned for the same heat output. The upgrading of standard boiler systems and associated controls in traditional buildings can be a relatively straightforward process with little negative impact on historic fabric. Condensing boilers are much more efficient and smaller than older ones and, when combined with appropriate controls, have the potential to deliver significant increases in energy efficiency. Wood pellet boilers are also a low carbon replacement for existing boilers. Care should be taken

regarding the location of any new boiler as the flue vents may have a negative impact on the external appearance of the building and may not be considered acceptable. To benefit fully from a high efficiency boiler, the heating controls in a building should also be upgraded to include thermostatic radiator valves (TRVs), room thermostats, heating zones, water heating on a separate time and temperature control, a programmable timer, boiler interlock and load compensators or weather compensators. If a building is fitted with a high efficiency boiler it is more efficient to run summertime water heating off the boiler rather than an electric immersion heater provided that the hot water circuit can be separated from the heating circuit. The lagging of all pipes carrying hot water is also cost effective, but may be difficult to implement in an existing building where many pipe runs are located below floors or within ceiling spaces.

WOOD BURNING

Many traditional buildings have chimney flues that could be used to advantage with wood burning stoves. A stand-alone stove as a replacement for an open fire would not normally have a boiler but there are a limited number of small stand-alone room stoves available with integrated boilers that can be connected to radiators and a hot water system. Stoves can be up to 80% efficient as opposed to the 30% efficiency of an open fire and can be used to burn logs that are sourced locally. The burning of timber is considered to be carbon neutral as trees absorb carbon dioxide while growing. However, in the case of pre-dried timbers or wood pellets, the timber may no longer be carbon neutral. Consideration should be given to the embodied energy already contained in wood if purchasing kiln-dried timbers or if using processed wood pellets imported from a distance (wood pellets are commonly imported from central Europe). Larger wood-burning boilers are also available and these are usually located remotely from the building in an outhouse with a wood storage area and a hopper for automatically feeding the boiler.

Fuel storage requirements for pellets and logs can be substantial and the construction of a new storage structure within the curtilage of a protected structure or in an architectural conservation area may require planning permission.



Wood-burning stoves can be efficient but in a traditional building they should generally only be fitted into non-decorative fireplaces. Historic grates and fire surrounds should not be damaged or removed in order to fit a stove

ELECTRICAL SERVICES

The use of electricity as a source of energy for heating is generally inefficient due to losses in generation, in distribution and in the appliance itself, with high resultant carbon dioxide emissions per unit of heating output when compared to oil or gas heating systems. The use of electric heating will also have a negative impact on a building's Building Energy Rating, as it is deemed to be inefficient and carbon-intensive: this may change in the future with increased use of wind and hydro-power. However, in the context of a historic building or a protected structure, the installation of wiring for an electrical heating system may be much less intrusive than a piped water-heating system, with no risk of damage to the fabric of the building from water leaks. Storage heaters are relatively cheap to purchase and can use night-rate electricity effectively (the use of which has some positive environmental implications). They can also exploit the high thermal mass of an existing building and, when coupled with appropriate draught-reduction and insulation and modern control systems, can prove to be an optimum solution for heating a historic property. Similarly the use of panel heaters with a shorter response time, perhaps used in tandem with storage heaters, or convector heaters/coolers could be considered. The location of cable runs either above or below floors (surface-mounted or otherwise) will need careful consideration to ensure minimal damage to fabric, in terms of both visual and physical impacts.



A storage heater fitted in a Georgian house. The low height of the storage heater allows for operation of the shutters at night and does not block the window

HEAT RECOVERY

Most heat recovery systems for domestic situations rely on a managed ventilation system, based on electrically powered fans, in the context of tightly sealed new buildings. As discussed previously, there is concern that significantly reducing ventilation within a traditionally built building may cause moisture problems within the fabric and in rooms. It seems unlikely that a heat recovery system in a predominantly naturally ventilated building would be either cost- or energy-efficient. In addition, any mechanical system that relies on ductwork will probably encounter difficulty as the relatively large ductwork would inevitably entail unacceptable levels of disturbance or loss of historic fabric or give rise to visual impacts. In the case of a protected structure, such works would probably require planning permission.

RENEWABLE ENERGY TECHNOLOGIES

Upgrading the fabric and services of an existing building are usually the most cost-effective means of improving its energy efficiency. However, there are instances where, to achieve greater energy savings and reduce carbon dioxide emissions, the use of renewable energy technologies could be considered for small-scale generation of electricity. So-called 'micro-renewables' include small-scale devices for exploiting sun and wind power, and heat within the ground, as well equipment for using renewable fuels such as timber, biomass or wood pellets. At present, the economic case for installing micro-renewables is not strong in terms of payback through cost savings. High capital costs result in lengthy payback periods which often exceed the lifespan of the installations.

However, in the medium term, market forces are expected to drive down the costs of installing renewable energy technologies, shortening the payback periods, thus making the installations more cost effective.

In the context of relatively high demand for energy within a particular building, the payback time on space-heating equipment which uses renewable energy, such as biomass or heat pumps, will be shorter. They should also assist in cutting carbon emissions.

Using simple solar-powered water heaters for domestic hot water is probably the most effective way to actively exploit solar power. Solar panels when mounted on the roof of a traditional building can be visually intrusive; a roof slope with a southerly orientation, not visible in important views of the building, is ideal such as within the valley of a roof. Such an installation can be reversed without causing significant damage, and so may be suitable for use on protected structures and within architectural conservation areas, subject to planning permission. It should be remembered that solar panels require an enlarged water cylinder.



A roof valley may be an appropriate place to locate solar thermal or photovoltaic panels provided that the orientation of the roof is appropriate. This image shows solar panels installed in hidden roof valley as part of Changeworks' Renewable Heritage project (Image © Changeworks)

The installation cost of a typical photovoltaic array for a dwelling is still relatively high. Small-scale wind-turbines are unlikely to offer any benefit in an urban environment although well-located installations, with a good exposure to wind, may be worthwhile in a rural situation. Power from such an installation could be used for water heating or background space heating. Wind turbines generate a large amount of vibration in use and are subject to high wind loadings and these must be taken into account if considering attaching

one to an older, possibly fragile, building. Also, the visual impact of a wind turbine on a historic building may be unacceptable. It is recommended that the building be checked for structural stability by an appropriately qualified professional before a wind turbine is attached.

Small-scale combined heat and power plant (CHP) can be very efficient in institutional or commercial buildings with high and consistent heat demands such as hospitals, nursing homes or hotels.

The installation of micro-renewables on a protected structure is not considered exempted development if it would have a material effect on the character of the building. The architectural conservation officer in the local authority should be consulted when considering any works.

HEAT PUMPS

Heat pumps work on the same principle as a refrigerator, drawing heat from a source, sometimes the air or ground water or the soil, and putting it into water or, less commonly, air. Such heat pumps work best serving as a source of heat for underfloor heating, where the water temperature required is lower than for radiators. Normally they are driven by electricity and are often claimed by their manufacturers to have the ability to convert one unit of power into three units of heat, thereby making the use of electricity for space heating more economic. If properly designed and installed, heat pumps may represent a carbon-efficient form of space heating. Systems should be designed for appropriate applications for all weather conditions.



Air-to-water heat exchangers: a heating system provided to a converted stable building. The grey metal casing will be camouflaged by future planting

As heat pumps are usually only appropriate for use with underfloor heating the retrofitting of this type of system is difficult. This type of upgrading should usually only be considered in the context of large-scale refurbishment works. Where the installation would involve loss of historic fabric it may not be suitable in a protected structure and planning permission would most likely be required. It is also worth noting that the appearance of air source heat pumps, which are large and industrial-looking, may not be appropriate sited adjacent to a traditional building and their location will therefore require some careful consideration.

LIGHTING

Many traditional buildings were designed for optimum use of daylight; effective use of daylighting can reduce the need for artificial lighting. Careful design of switching arrangements and other controls for lighting such as occupancy detectors are effective ways of reducing energy use in buildings.

The most efficient sources of artificial light are fluorescent tubes (which use 80% less energy than traditional incandescent bulbs) and light emitting diodes (LEDs). As compact fluorescent lamps (CFLs) emit higher levels of ultra-violet light which leads fabrics and papers to fade, consideration should be given to the potential impact on a room's decorative finishes and furnishings prior to switching from traditional incandescent bulbs. Recently developed halogen lights use less energy than incandescent bulbs but do not cause the same problems with fading as CFLs. According to the marketing information these halogen lights use 30% less energy than traditional incandescent but have a similar appearance and may be more appropriate in formal rooms and older types of light fittings. In this regard, it should be noted that some light fixtures in protected structures may be important features in themselves and modification of them may require planning permission.

Principles for improving the energy efficiency of a traditional building

- > Consider the microclimate and respond as appropriate: take advantage of the sun, create protection from the wind and keep buildings well-maintained and dry
- > Ensure the nature of use is suitable for the building as a whole or for particular rooms within a building. In some cases, it may be appropriate to re-arrange the locations of activities within a building
- > Evaluate the energy requirement in the context of embodied energy and life cycle costs as discussed in Chapter 1
- > Understand why and where heat is lost. Recognise energy-efficient design features in traditional buildings and endeavour to retain and improve these features
- > The principle of minimal intervention should apply when undertaking works to upgrade the energy efficiency of a historic building. Retain and repair the existing fabric of the building rather than replace it
- > Prioritise the order in which building elements are to be upgraded, taking into consideration both the character of the historic fabric and the upgrading works which will provide the greatest energy savings when compared to the investment costs. In general, for a traditional building, the priority order will be as follows:
 1. Draught proofing of windows and doors
 2. Roof insulation
 3. Replacement of outdated services with high efficiency units and updated controls
 4. Repair of shutters and fitting of curtains, with the possible installation of secondary glazing
 5. Floor insulation
 6. Wall insulation
- > Follow the principles of passive design when making any modifications. If constructing an extension to an existing building, take full advantage of passive design using this new addition to incorporate elements such as micro-renewables, which can serve both the new and old parts of the building. However, bear in mind that it may not always be appropriate or practical to add to the older building

4. Case Studies

These case studies demonstrate how measures to improve energy efficiency have been implemented in a variety of historic buildings without negatively impacting on the architectural character of each building. In addition they show how, by following the conservation principle of minimal intervention, a sustainable level of intervention can be achieved in terms of the cost of works and the amount of energy to be consumed by a building over its prolonged life.

A Regency house in the city



The brick façade from 1821 was later repointed using a sand and cement mortar. While the removal of this pointing and its replacement with a vapour-permeable lime-based mortar would benefit the building, it is likely that the process of removal of the pointing would cause unacceptable damage to the brickwork

DESCRIPTION OF THE BUILDING AND SITE

The house faces south-west, and is in the middle of a terrace of similar houses. This early-nineteenth-century house has been modified many times over its lifetime. The original layout comprised two rooms on each of the lower two levels with a three-bedroom layout on the upper floor. A 'flying bathroom' was added on the

return level of the original stairs and later removed. The building, like so many in the inner suburbs, was converted to flats in the 1960s and extended at that time with a flat-roofed extension to the rear. Following re-conversion to a single dwelling in the late-1980s, the roof was raised to provide a further habitable floor. The building extends to approximately 220 m².

This is an example of a house which has been adapted many times to meet changing requirements. It is now a protected structure and any works that would materially affect its character require planning permission.

WORKS CARRIED OUT

Recently constructed elements such as the attic storey were built to the requirements of the building regulations. This means that the roof and much of the back wall have higher U-values than the original structural elements. Works to the house included replacement of the basement floor in concrete, with insulation beneath the slab. The roof has a typical modern slated construction, with a high performance insulation board laid between the rafters, laid over foil-backed plasterboard. The flat roofs are covered in asphalt and insulated with a fibreglass quilt. The original brick wall above basement level, which is the main façade, was repointed in sand and cement in the 1960s. This has interfered with the ability of the wall to 'breathe', that is, to allow water to evaporate, and thus the wall is colder than a comparable wall pointed in a lime-based mortar.

In common with many such buildings, the basement walls are thicker and are constructed of granite in a lime mortar. The granite, being dense, is a colder material than the brick and conducts heat more rapidly. New windows are double glazed in a timber frame, while original windows, where existing, are single glazed with working shutters. No draught proofing has been applied to the windows.

SPACE HEATING AND HOT WATER

A gas boiler provides heat to radiators and a hot water cylinder. In addition, an open fire is lit in the main living room and a solid fuel stove is used in the basement family room.

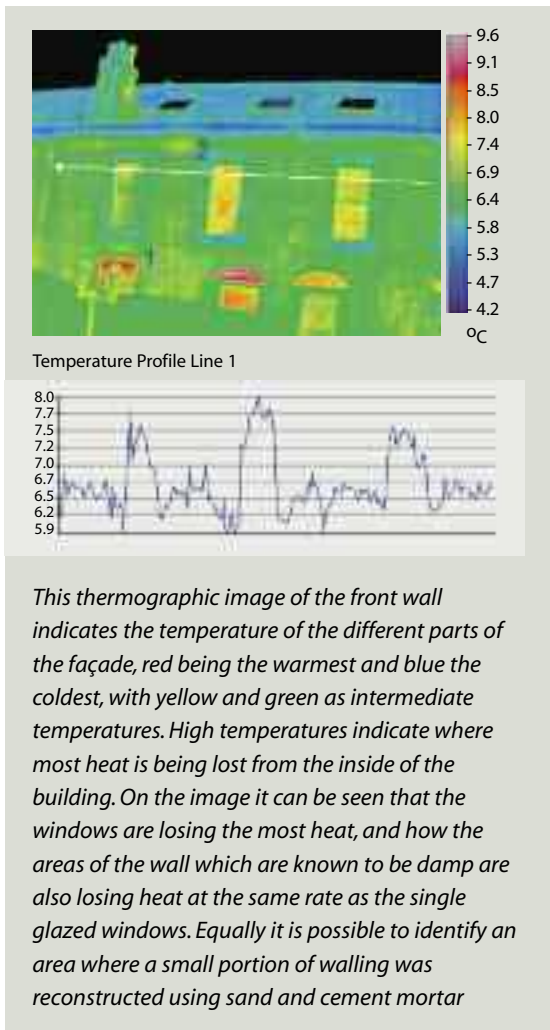

ENERGY ASSESSMENT

Being in a terrace, the house benefits from the lack of exposure of its flanking walls. The configuration of the house, being approximately a cube, means that heat loss through the walls is low and the heat loss through the roof and basement floor is comparatively low given high standards of insulation and a relatively small 'footprint' of the building relative to its overall floor space. The orientation of the house means that it enjoys some solar gain through its front windows and it is sheltered from the prevailing winds by mature trees located about twenty-five metres away. The building has a typical family-based level of activity, with continuous light daytime occupation and more intense morning, evening and night-time usage. Shutters are used to reduce heat loss through the historic single glazing at night-time, while there are lined curtains on some windows.

CONSERVATION ASSESSMENT

This hybrid construction, combining historic and modern fabric, is relatively common, particularly as many older houses have been renovated or extended in recent years. Conservation considerations have meant that the main windows have been retained and that no dry-lining has been applied to the walls of the house while surviving original fabric has been retained throughout.

LIFECYCLE ASSESSMENT

The cumulative effects of the various works that have been undertaken in recent years mean that it is in good condition with a re-slatted roof and new back wall. These elements of the house should not require further works for another 50-70 years. Windows and cast-iron rainwater goods will require on-going maintenance every 5 years.

RECOMMENDATIONS

Some draught proofing could be added to the existing historic sash windows. Gaps between the window frame and the wall should be caulked to minimise leakage. Dampers could be provided to all chimneys to moderate ventilation rates. For architectural conservation reasons, there is little potential for the provision of porches or draught lobbies either internally or externally. The removal of the cement pointing and its replacement with a vapour-permeable, lime-based mortar would improve the thermal performance of the front wall by reducing its moisture content. However, the potential for damage to the brickwork, and the relatively high cost of such work make repointing undesirable from a conservation point of view and financially unviable. When the present gas-fired boiler reaches the end of its life, a new high-efficiency condensing boiler with new heating controls could be provided. The hot water cylinder should be on separate time and temperature control. Pipework should be insulated where accessible. All incandescent light bulbs should be replaced with low energy bulbs.

A detached country house



When compared to buildings in other northern European countries, Irish buildings generally have comparatively small windows in proportion to the walls

DESCRIPTION OF THE BUILDING AND SITE

This is a fine two-storey over basement country house, primarily dating from the early-eighteenth century but with nineteenth-century additions. The building is a protected structure and is in use as a private dwelling. The floor area of the house is approximately 300 m².

The layout of the house is quite compact, having a central entrance hall, with rooms to either side, leading to a stair hall, which originally projected from the rear wall, but was later partly flanked by the nineteenth-century extension to the rear left. The house retained much of its original joinery and plasterwork but was in need of repair. Walls are constructed in rubble stone and rendered externally.

The siting of the house demonstrates a good understanding of the benefits of shelter-belt planting, having a large copse extending to the west with farm buildings and more trees extending to the east. The façade of the house itself faces due south.

A programme of repair works has been ongoing at the house for a number of years, benefitting from grant assistance from the local authority conservation grant scheme, the Heritage Council and the Irish Georgian Society.



This first edition Ordnance Survey map shows a more extensive stand of trees to the northeast, with several clumps of trees ornamenting the front paddock and modifying the impact of the occasional mild southerly gale

WORKS CARRIED OUT

Generally, essential repairs to the external envelope of the building have been carried out on a sequential basis. Typically a dry house is a warmer house and with that in mind, the roofs were re-slatted, parapet gutters re-leaded, chimneys re-rendered and defective rainwater goods repaired or replaced - all with a view to reducing the level of dampness in the house. Ceilings under the attic have been insulated. Original window frames have been repaired and, where sash windows had been replaced with inappropriate twentieth-century ones, these were replaced with sashes to match the original. No draught proofing has been installed as the newly fitted sashes are quite snug, while still admitting sufficient trickle ventilation.

SPACE HEATING AND HOT WATER

An oil-fired aga cooker was fitted in the new south-facing kitchen/dining room. The nineteenth-century wing is heated by an oil-fired central heating system. An electric hot-water immersion cylinder is also used.

ENERGY ASSESSMENT

This house represents the implementation of a series of measures which can significantly improve the energy efficiency of a traditional building. The combination of attic insulation and new or repaired windows together with its south-facing orientation have helped significantly to exploit the thermal mass of the building in retaining solar heat-gain. Virtually all rooms have fireplaces, which have been kept open. The relocation of the main kitchen from the north-facing rear room to a sunny east and south-facing room made a significant improvement to the daily comfort of the occupants.

CONSERVATION ASSESSMENT

Works which have been carried out for the benefit of the structural integrity of the building have also increased the building's thermal performance. No insulation has been added to the walls of the building but, by keeping them dry, the building stays warmer and retains heat better. The omission of draught proofing from the windows means that they admit more ventilation, which helps to dispel high internal moisture levels which could cause or promote the growth of mildew, rots or other fungi.

LIFECYCLE ASSESSMENT

More than 260 years old, the original finishes still survive internally. The newly re-slatted roof has a design life of a hundred years. The new timber sash windows, with normal maintenance, have a life expectancy in excess of 100 years.

RECOMMENDATIONS

The house should be re-rendered with a lime based render, which would further reduce the moisture content of the walls, keeping them warmer. In a rural location with sufficient space for storage of fuel, a wood-pellet boiler may be considered, or a more labour-intensive wood-burning boiler, which could exploit timber harvested on the farm. In the less-architecturally important rooms, provision of small timber burning stoves could be considered; these would do away with the need for central heating pipework, with the potential for damage to the fabric of the building. For those areas served by the central heating system, the different zones and the supply of hot water should be time and temperature controlled from a central programmer. There should also be a boiler interlock and, for a large house, a compensator circuit. The installation of an optimiser control that senses outside temperature should be considered. All hot-water pipework should also be insulated. Temporary sealing through the use of dampers on unused chimneys would reduce infiltration losses. Where appropriate, traditional light bulbs should be replaced with energy-efficient ones.

A pair of rural cottages



Cottages prior to refurbishment

DESCRIPTION OF THE BUILDING AND SITE

These small lodges, which are protected structures, had fallen into disrepair before undergoing refurbishment and enlargement. Small simple buildings such as these are most vulnerable to over-renovation, where their character can be lost.

WORKS CARRIED OUT

Poorly built modern extensions to the cottages were replaced with modern, highly insulated extensions with window openings primarily facing east and west. Sun rooms were added on the south side of the houses, providing pleasant living spaces and contributing to the solar gain of the buildings in their entirety. As the cottages are semi-detached, the new extensions to north and south leave only one exposed original wall in each cottage. The ground floor was excavated and a new, insulated floor laid while the roof was insulated as part of the re-slating works. Historic leaded single-glazed windows have been retained and repaired. As a result of the repairs these windows have a snug fit and have not required draught proofing. Where existing, original shutters were brought back into use. New timber double-glazed windows, some with shutters, have been provided elsewhere. External render was replaced in a lime-based render which matches the original. A French drain was provided around the building to help reduce the moisture content at the base of the external walls.

SPACE HEATING AND HOT WATER

New gas-fired condensing boilers have been provided and serve underfloor heating and radiators. Each house has three heating zones with separate thermostats. All radiators have been fitted with thermostatic radiator valves. Wood-burning stoves have been fitted in the living room fireplaces and these chimneys are therefore still in use.

ENERGY ASSESSMENT

These houses have modern standards of insulation in the floor and roofs. While the walls have not been upgraded, the new extension to the north side of the building has modern insulation standards thereby keeping the coldest part of the buildings warm. The sun rooms to the south will collect heat from the sun and this heat will gradually spread through the house during the day. As the sun rooms are separated from the rest of the house with external-quality double-glazed doors they can be isolated in the evening and during the winter. The radiators in the sun rooms, on a separate circuit to the remainder of the house, can be controlled independently. The shutters keep in the heat at night time.

CONSERVATION ASSESSMENT

The cottages have been upgraded in a manner which achieves a balance between improving energy efficiency whilst retaining the essential character of the historic lodges as well as their building elements and materials.

LIFECYCLE ASSESSMENT

The new roofs, using high quality natural slate and leadwork, should have a design life of 70-100 years subject to regular maintenance of the rainwater goods.

RECOMMENDATIONS

Having upgraded the cottages and introduced a range of energy-efficient measures, the buildings should be kept in good repair and maintained in an appropriate fashion.

A converted stable yard



Before and after images of restored stable yard

DESCRIPTION OF THE BUILDING AND SITE

This is a stone-built stable yard arranged around four sides of a courtyard. The stable yard is a protected structure and, prior to refurbishment, it had fallen into an almost completely ruinous state. The footprint of the building is extensive and the ranges are long and low with a shallow plan from front to back. The building is set low in relatively open landscape but with a copse of trees planted on its west side.

WORKS CARRIED OUT

The complex has been subdivided into a group of ten houses. As part of the restoration of the courtyard, the building was re-roofed, with high levels of insulation provided. New windows were installed in both single and double-glazed arrangements. Where existing windows survived, these were repaired and fitted with single glazing. The design of all the new windows was based on evidence of pre-existing four-pane windows. These new windows are double-glazed casement windows. The solid rubble limestone walls were repointed with a lime mortar in order to ensure high levels of breathability while a new insulated floor slab was laid with an injected DPC being provided at low level to the original walls. New, well-insulated extensions complying with the building regulations were provided to four of the houses. This has internalised part of the north wall of the complex, making that wall warm and dry.

SPACE HEATING AND HOT WATER

Each house is served by an air-to-water heat pump, which provides heat for underfloor heating at ground and first floor levels through the houses, as well as domestic hot water. Every room in each house is thermostatically controlled. Each heating system benefits from a weather compensator, which modifies the output in accordance with the external air temperature.

ENERGY ASSESSMENT

Refurbishment of an existing ruin is sustainable development in that it retains embodied energy by the reuse of a structure which has already had a 200-year life. The new floors and roofs have been insulated to modern standards and many rooms within the complex have double-glazed windows. The heating system is designed for optimum efficiency.

CONSERVATION ASSESSMENT

Having fallen into dereliction over a period of several decades, this building has now been comprehensively restored and refurbished and is being put to a new and sustainable use. The essential character of the stone-walled, slate-roofed structure has been maintained with modifications to its architectural form being kept to a minimum while at the same time ensuring suitable comfort standards.

LIFECYCLE ASSESSMENT

The building complex has been restored to high conservation standards with natural slate roofs, new floor substrates and new floors all of which have an anticipated 100-year life. The windows and cast-iron rain-water goods will require regular maintenance. The air-to-water heat pumps have a life-expectancy of 15 years.

RECOMMENDATIONS

Having upgraded the courtyard buildings and introduced a range of energy-efficient measures, the building should be kept in good repair and maintained in an appropriate fashion. As the use of air-to-water heat pumps is relatively new to Ireland, it would be interesting to monitor the performance of the system over a number of years and calculate the energy savings achieved.

A mixed-use building in a town



Tall, south-facing windows allow the main hall to be flooded with light and maximise solar gain

DESCRIPTION OF THE BUILDING AND SITE

This detached building is two-storeys in height over a basement and has an additional attic storey set behind a parapet. The corner stone was laid in 1703 and the building completed by 1707. However, it is believed to incorporate fabric from a seventeenth-century building that previously occupied the site. The seven-bay brick façade is asymmetrical with a corresponding asymmetrical plan. Accommodation to the west side includes a basement, double-height hall and attic, while the east side has accommodation over the basement, ground, first and attic levels. The staircase is contained in a projecting compartment at the rear of the building. A single-storey extension was built c.1995 on the north side of the hall to the east of the staircase projection.

This building is a protected structure. It comprises a series of large rooms that are used for private functions with ancillary kitchen and WC accommodation. Office accommodation is located in the smaller rooms within the attic storey and first floor of the building. The building is approximately 300 m² in area.

The interiors have changed considerably during the course of the last three hundred years. In particular, dereliction during the middle period of the twentieth century resulted in considerable loss of architectural features. Today the most important surviving feature is the original timber staircase. The ground, first and second floors are of timber joisted construction with floorboards supported by beams or load-bearing walls. The basement floor consists of modern tiles on what is understood to be an uninsulated 1970s concrete slab. The walls of the basement are of calp, a dense limestone, which has been stripped of its internal plaster, while the walls of the upper storeys are of brick, exposed externally and plastered internally.

The existing pitched roof is finished with natural slate. The interior of the roof space was originally built to accommodate habitable space with dormer windows provided in the roof. These rooms are in use as offices today, retaining dormer windows with dry lining to the walls and the underside of the roof. The roof-space contains some fibreglass insulation. The existing windows and doors date from the 1970s and are replicas of the historic sash windows.

WORKS CARRIED OUT

Having undergone a significant restoration in the 1970s, the building has been the subject of periodic maintenance and repairs since that date. Recently, repairs and draught-proofing works have been carried out to the windows and there has been some upgrading of services.

SPACE HEATING, HOT WATER AND ELECTRICITY

The building has recently been fitted with an efficient gas condensing boiler resulting in immediate savings in terms of energy consumption. However, the distribution pipework is old and in need of upgrading. Hot water is provided locally from under-sink electrical units; this can be an efficient solution where water demand is sporadic. Prior to carrying out full-scale replacement of the existing pipes, an assessment of any potential damage to the fabric should be completed and if it is found that this work would result in further damage to the fabric it may be more appropriate to modify the existing pipework without general replacement.

ENERGY ASSESSMENT

This is a free-standing building with relatively thin walls and extensive single-paned glazing. While it benefits from a southerly orientation the building has a high heating requirement. The building enjoys good natural daylight from the south with large window openings and fewer openings on the north elevation. There are fireplaces at basement and main floor level in the north wall, while the staircase is also on the north side. The single-glazed southerly windows are advantageous as they allow for maximum amounts of solar gain. The windows and doors, prior to draught proofing, provided ventilation levels above the required 0.8 - 1 air change per hour. This was especially noticeable in the smaller office spaces at the top of the building, which were difficult to heat, and had a negative impact on comfort levels.

CONSERVATION ASSESSMENT

While the building was substantially renovated in the 1970s, it retains much of its original fabric and spatial character. The recent upgrading works to the building have been achieved with the maximum retention of historic fabric and no noticeable impact on the character of the building.

LIFECYCLE ASSESSMENT

Built in 1703-7, the building is now more than three hundred years old. The brickwork, being mainly original, has discounted its embodied energy over its long lifespan. The slating has been repaired a number of times, but is nearing the end of its useful life.

RECOMMENDATIONS

As the basement floor is modern, there is the potential to replace it with an insulated slab incorporating underfloor heating powered either by natural gas or connected to a source of renewable energy. However, digging up the basement floor would be a costly exercise, which would only make financial and environmental sense if undertaken as part of a larger project to refurbish the basement and enhance the architecture, thereby going some way to mitigate the cost both financially and in relation to embodied energy. Given the location of this building, and the fact that it incorporates fabric of an earlier building, there may be archaeological implications to such works which would impact on the decision-making process.

Windows at attic level have been draught proofed. As the upper level of the building is partially within the roof space, the amount of insulation which can be retrofitted may be limited owing to the construction type of the roof and spatial considerations in the attic. Under these circumstances a combined approach needs to be taken with scope for lining the interior at this level with insulation in tandem with filling the void above the ceiling level with insulation where accessible. This would provide the maximum achievable levels of roof insulation. A range of insulation materials could be considered for use in such circumstances, with possibly more than one type being required for different applications. The building's owners may have a preference for natural products such as wool or hemp over synthetic products.

As with many historic buildings, the potential for applying insulating materials to the interior face of the walls is limited. The basement walls have been stripped of their plaster, and a lime plaster finish could be reinstated which would have a higher surface temperature than the cold exposed stonework. Lime plaster would also absorb and release moisture, modifying humidity and adding considerably to the sense of comfort within the room. Energy-saving works which are carried out to the walls should also concentrate on ensuring the walls are dry by repointing them with lime mortar and re-plastering with breathable lime plaster where necessary.

While some windows have window shutters, others do not. In the case of the latter, consideration could be given to providing new window linings with working shutters. The shutters could be used at night time to help retain heat gained in the building during the day.

There may be some scope for inserting secondary glazing panels inside the windows for the winter months. These would be visually less obtrusive if a relatively plain system (possibly in the form of two sliding panels in a light aluminium frame) were installed. This would allow ventilation as required, and permit access for cleaning purposes.

Prior to draught proofing windows and doors, an assessment of all means of ventilation of each room should be completed to allow for proper consideration and design for maintaining the minimum number of air changes per hour in spaces that are heavily used. Provision should be made to allow additional ventilation to ensure that moisture and humidity levels are controlled.

This building has historical importance which is an over-riding consideration in the context of energy savings. It would be best upgraded as follows:

- > Through maintaining the building and ensuring that the external walls are drier
- > By improving roof insulation
- > By fitting removable secondary glazing
- > By reviewing electrical usage to provide light and small power. Controls for lighting in this building could be examined. Occupancy and daylight detectors could easily be fitted
- > Future development of the complex may provide opportunities for more appropriate fitting of sustainable energy installations and for adding extensions which, by their presence, could somewhat reduce the heating requirement of the existing building. However, the restricted nature of the site and the architectural significance of this building would make the design of an appropriate extension very difficult

Living over the shop



Although this traditionally built building is not a protected structure, it has been refurbished in accordance with best conservation practice

DESCRIPTION OF THE BUILDING

This is a late-nineteenth century building, two-storeys high over a basement with an inhabited dormer attic storey, a first floor having tall windows and a ground floor with a shopfront. It was originally built of brick and stone, with a rendered finish to the rear façade. A new return built in 2000 was constructed using a proprietary metal system which has external insulation as well as insulation between the metal studs. The return extends over half of the original north-facing rear wall. The building now comprises two two-bedroom apartments with office use on the ground and basement floors. The original windows are single-glazed vertically sliding sashes.

WORKS CARRIED OUT

At the time of its redevelopment in 2000, the basement floors were replaced with a concrete slab having an insulated screed containing a piped underfloor heating system. Floors throughout the remainder of the building consist of timber joists with timber floorboards; new ceilings were added between the shop floor and the apartments above, insulated with mineral wool, primarily for fire separation purposes, but which also has advantages in terms of reducing noise transfer. The roof was re-slatted and provided with insulation to building regulation requirements. At attic level, mineral wool insulation was provided over the flat ceilings while insulation board was provided to the coved areas. The original walls of granite rubble and brick were left uninsulated.

The highly insulated extension on the north side was constructed of steel studs with insulation between, and with external insulation finished with a proprietary render to the exterior. New windows are timber framed with double-glazed units. The original windows were repaired but not draught proofed. No shutters were provided. An earlier aluminium shopfront was removed and replaced with a new timber-framed double-glazed shopfront.

SPACE HEATING, HOT WATER AND ELECTRICITY

There are individually controlled, gas-fired, combination boilers to each apartment and the ground floor offices. The common areas are unheated.

ENERGY ASSESSMENT

Having individual heaters for each tenant gives a high degree of control over the use of energy and is an efficient way of delivering heat to each tenant. The building is part of a terrace which reduces the amount of external wall and related heating load, while the highly insulated new extension on the north side reduces heat loss through the north wall by half by 'internalising' the older masonry wall over half its width.

CONSERVATION ASSESSMENT

The importance of this building arises from its contribution to the character of the streetscape. The building maintains its original appearance to the street, except for the modern part of the shopfront.

LIFECYCLE ASSESSMENT

Now approximately 130 years old, the refurbishment works of 2000 should mean that this building will have a further life of fifty to a hundred years before re-slating is required. General maintenance works to windows and cast-iron gutters will be required every five years.

RECOMMENDATIONS

Appropriately designed and accurately detailed shutters should be provided to all the original windows which remain single-glazed.

A Georgian townhouse



A well-maintained Georgian house with its original timber-framed sash windows

DESCRIPTION OF THE BUILDING

In common with most city-centre Georgian houses, this building is now used as offices by a number of different tenants. It is located in the middle of a terrace, faces north, and comprises four storeys over basement, with a typical floor plan having two rooms per floor for the ground and first floor, the equivalent rooms being subdivided to form four rooms on the upper floors. The basement is used as a conference room. A return structure is used as a residence. The plan form of the building is compact, with a relatively small amount of exposed external walling to the front and rear.

WORKS CARRIED OUT

The windows were provided with draught excluders and the shutters were eased and adjusted to allow them to be closed at night for security and insulation purposes. After a short period of usage, some of the draught excluders were removed to reinstate trickle ventilation into the rooms to counteract the effects of excessive heat given off by electrical office equipment.

SPACE HEATING, HOT WATER AND ELECTRICITY

All heating is by electrical heating. Consideration was given during recent refurbishment to the installation of a radiator-based system. However, the impact on the historic fabric of the installation of the required pipework would have been far greater than the impact of wiring for storage heaters. Used judiciously, storage heaters with convector fans can be cost effective in traditional buildings, where they exploit the greater thermal mass of such buildings. Individual control on a floor-by-floor basis means that the rooms are only heated as required. The stairhall is not heated.

ENERGY ASSESSMENT

Windows have been draught proofed and electrical heaters upgraded to high-efficiency commercial storage heaters, which fit under the windows, replacing older storage heaters and inefficient plug-in heaters. As the building is in commercial use, the storage heaters are an effective way of heating the spaces, providing heat efficiently during the day. The shutters are all in working order and used at night time to retain the heat which has built up during the day. This building achieves comfort for a range of different building users, who control heating levels in each separate occupancy. The mid-terrace location means that aggregate heat loss is relatively low.

CONSERVATION ASSESSMENT

Selective structural repairs were carried out to this building, but apart from the conversion of the basement to use as a lecture theatre, there has been little alteration of this building. Much of the original fabric has survived, the building having a resultant high degree of architectural authenticity.

LIFECYCLE ASSESSMENT

Now over 200 years old, this building is in good condition and the recently completed structural repair works will safeguard it for the foreseeable future. The roof has not been re-slatted in recent years and this may need to be undertaken within the next 30 years. General maintenance works to windows, cast-iron gutters, and cast and wrought-iron railings will be required every five years.

RECOMMENDATIONS

The existing insulation in the roof space is minimal and should be upgraded where roof spaces or lofts are accessible. Where ready access to loft spaces is not possible, for example because of the lack of access hatches, insulation provisions should be reviewed as part of any future re-roofing works.

Places of worship

A typical place of worship has decorative finishes both internally and externally; rich with traditional materials and details, they can be difficult to upgrade. In general, the most appropriate energy-efficiency measures for churches and cathedrals are the insulation of the roof and the improvement of the mechanical and electrical services.

The upgrading of roof insulation is generally straightforward where there is an attic in a building; however, places of worship often have exposed undersides to roofs, the upgrading of which requires careful consideration. Where a place of worship has a flat ceiling, it is generally possible to insulate above it. Such insulation is inexpensive to install and has the effect of moderating heat loss so that temperature fluctuations between heating cycles are less extreme; sudden changes in temperature can be damaging to historic building fabric. Given that churches are often only heated at weekends, it could be argued that there is a long payback period on the investment in insulation; this needs to be considered on a case-by-case basis. The episodic and variable way in which such buildings are used also results in particular requirements for its heating and lighting systems.

Caution should be exercised to ensure that any electrical wiring in the roof space is in good condition if it is to be enclosed by insulation. In some cases it may be advisable to have wiring inspected by an electrician on the Register of Electrical Contractors of Ireland (RECI) before proceeding with installing insulation. It is also very important to ensure that any lights recessed into the ceiling have adequate ventilation or fire-covers fitted before laying insulation.

Improvements to the heating system such as replacing a boiler and installing better controls are good actions to take. While it may seem extravagant, it is important to seek to maintain the temperature of the church at a reasonable level, probably over 12°C, throughout the week, so as to avoid condensation and damp-related problems and to make it easier to achieve a comfortable temperature during weekend services.

A nineteenth-century rural church



A nineteenth-century church with spire. The roof has been re-slatted and insulated and the walls re-pointed

DESCRIPTION OF THE BUILDING AND SITE

This church dates from 1870 with various alterations and additions having been made since. In plan, the church comprises a three-bay nave with a tower and a porch attached to the south west corner. A wide chancel arch leads to the two-bay chancel while a robing room adjoins the chancel on the south side. The church has been well maintained over the years.

BUILDING USE

This church is usually used only twice a week for services. During a recent programme of works to improve the weathering of the building it was decided also to undertake works to improve its energy consumption and to increase the thermal comfort of the building's users.

WORKS UNDERTAKEN

The roof was re-slatted with new Bangor Blue slate. While re-slating the roof the opportunity was taken to add a layer of insulation using a very thin layer of reflective material between the slates and the ceiling boards. This resulted in a slightly raised roof which was accommodated with secret valleys at the barges and raised gutters, supported by new stone insets. Walls were repointed in a lime-based mortar to reduce damp and internal lime plaster was repaired where necessary. All lighting was replaced with low energy metal halide lamps; with tungsten halogen lamps confined to the sanctuary area to allow for manipulation of the lighting levels.

Getting a gas supply to the site was not possible. The oil-fired boiler was replaced with a more efficient one and all pipework was replaced, lagged and fitted with modern controls. New radiators were installed along both walls of the nave at regular intervals to deliver quick response heat to all areas in a short period of time in accordance with the requirements of the users.

The result is a church which is draught-free with controlled ventilation and an efficient, quick-response heating system providing comfort levels when required.



A special detail was used to deal with the small additional height that resulted from adding insulation to the roof build-up; stone blocks were added under the reinstated cast-iron gutter



While re-slating, the opportunity was taken to put the original ceiling vents back into working order. The vents are mechanically controlled to allow the users to alter the amount of ventilation as required

An eighteenth-century city church



The church following restoration

This church is intensively used both during the week and at weekends. A programme of works was undertaken a number of years ago to refurbish the building for its current use. The building had suffered from serious damp ingress over time and required works to the roof, rainwater goods and stone façades. As part of these building works, an extension was added to the rear of the building and underfloor heating was provided. Mineral wool insulation was provided over the main ceiling. The existing single-glazed timber framed windows were repaired and refurbished but not draught proofed.

As this building has long periods of continuous use at a time, underfloor heating is an appropriate heating system. The low-temperature heat stored in the floor can help to combat ground damp in older buildings. High spaces such as are found in big churches are difficult to heat satisfactorily using radiators. By heating the floor, heat is provided where it is required; the convection of hot air is reduced, meaning that overall heat losses are reduced. However, as many places of worship have high quality flooring and, in some cases, burials beneath the floor, the installation of underfloor heating will often not be an option. The lifting of a historic floor in a protected structure is of course subject to planning permission. In this case, the existing floor was timber with some tiling at the perimeter but was in a dilapidated state and required replacement.



This new extension to the rear of the church provides necessary office accommodation and comprises two storeys built on top of the ruins of the original vestry



A timber glazed porch was provided inside the main west door, primarily for draught-proofing purposes but also to avoid having to re-hang the external doors, which would otherwise be required to open outwards for emergency egress

Historic buildings and the law

ARCHITECTURAL HERITAGE PROTECTION

Under Part IV of the Planning and Development Act 2000, buildings which form part of the architectural heritage can be protected either by being designated a protected structure or by being located within an architectural conservation area.

Where a building is a protected structure (or has been proposed for protection) or is located within an architectural conservation area, the usual exemptions from requirements for planning permission do not apply. In the case of a protected structure any works, whether internal or external, which would materially affect its character, will require planning permission. Legal protection also extends to the land and other structures associated with a protected structure such as outbuildings that are located within the curtilage of the main building. In an architectural conservation area, any works to the exterior of a building which would affect the character of the area also require planning permission. Owners and occupiers of protected structures have a responsibility to maintain their buildings and not to damage them or allow them to fall into decay through neglect.

A notice was sent to every owner and occupier of a protected structure when the building first became protected. If you are not sure of the status of your building, check the Record of Protected Structures in the Development Plan for the area. If your building is a protected structure, or if it is located in an architectural conservation area, your planning authority will be able to tell you what this means for your particular property.

As an owner or occupier of a protected structure, you are entitled to ask the planning authority to issue a declaration which will guide you in identifying works that would, or would not, require planning permission. Works to upgrade the energy efficiency of a protected structure, if carried out in line with good conservation practice and the guidance contained within this booklet, will generally not require planning permission if they do not materially affect the character of the building. However, some types of work may require planning permission. If you are in any doubt about particular proposed works, you should contact the architectural conservation officer in your local authority for advice.

For general advice on planning issues relating to architectural heritage, a publication entitled *Architectural Heritage Protection Guidelines for Planning Authorities* (2004) published by the Department of the Environment, Heritage and Local Government is available from the Government Publications Sales Office or can be downloaded from www.environ.ie.

TRADITIONAL BUILDINGS AND THE BUILDING REGULATIONS

Generally, an existing building is required to comply with the Building Regulations when it undergoes a material alteration or change of use. Technical Guidance Document (TGD) L is published by the Department of the Environment Heritage and Local Government to provide guidance on meeting the requirements for *Part L: Conservation of Fuel and Energy* of the Building Regulations. The guidance is published in two parts, one for the *Conservation of Fuel and Energy - Dwellings* and a second for the *Conservation of Fuel and Energy - Buildings other than Dwellings*. These documents set out a number of minimum standards for heat loss, thermal bridging, air infiltration and the efficiency of heating and cooling plant.

An existing building which is a protected structure or a proposed protected structure is exempt from the requirements of Part L (Conservation of Fuel and Energy) of the Building Regulations when it is subject to material alteration or a change of use. Buildings protected under the National Monuments Acts, such as recorded monuments, are generally exempt from the requirements of the Building Regulations. A number of categories of buildings are exempt from the requirements of the European Communities (Energy Performance of Buildings) Regulations 2006 which require a Building Energy Rating (BER) to be undertaken for an existing building when let or sold. These categories include buildings protected under the National Monuments Acts, buildings that are protected structures and proposed protected structures under the Planning and Development Acts and buildings used as places of worship or for the religious activities of any religion.

Any works that would affect the character of the building or have a material or visual impact should be carefully considered. In specific cases, relaxation of requirements may be acceptable to the local building control authority, if it can be shown to be necessary in order to preserve the architectural integrity of the particular building.

The Building Control Acts and associated Regulations apply minimum standards to the design and construction of extensions, alterations and change of use of existing buildings; responsibility for complying with the Building Regulations rests primarily with the owners, designers and builders of the buildings or works. The current Building Regulations and Technical Guidance Documents can be found at www.environ.ie.

Useful contacts

The architectural conservation officer in the local authority should be the first person to contact with queries regarding a historic building. Other useful contacts include:

Architectural Heritage Advisory Unit,
Department of the Environment, Heritage and Local Government,
Custom House, Dublin 1

Telephone: 01 888 2000

Web: www.environ.ie

Construction Industry Federation, Register of Heritage Contractors, Construction House, Canal Road, Dublin 6

Telephone: (01) 406 6000

Web: www.heritageregistration.ie

Engineers Ireland, 22 Clyde Road, Ballsbridge, Dublin 4

Telephone: 01 665 1300

Web: www.iei.ie

Heritage Council, Áras na hOidhreachta, Church Lane, Kilkenny, Co. Kilkenny

Telephone: (056) 777 0777

Web: www.heritagecouncil.ie

Irish Architectural Archive, 45 Merrion Square, Dublin 2

Telephone: (01) 663 3040

Web: www.iarc.ie

Irish Georgian Society, 74 Merrion Square, Dublin 2

Telephone: (01) 676 7053

Web: www.igs.ie

Royal Institute of the Architects of Ireland, 8 Merrion Square, Dublin 2

Telephone: (01) 676 1703

Web: www.riai.ie

The Society of Chartered Surveyors, 5 Wilton Place, Dublin 2

Telephone: (01) 676 5500

Web: www.scs.ie

Sustainable Energy Authority of Ireland, Wilton Park House, Wilton Place, Dublin 2

Telephone: (01) 808 2100

Web: www.seai.ie

Further reading

Baker, Paul. *In Situ U-Value Measurements in Traditional Buildings – preliminary results*. Edinburgh: Historic Scotland. (2008)

Baker, Paul. *Thermal Performance of Traditional Windows*. Edinburgh: Historic Scotland (2008)

BRECSU. *Post-Construction Testing – a professional's guide to testing housing for energy efficiency*. General Information Report 64. London: HMSO (2000)

Carrig Conservation et al. *Built to Last: the sustainable reuse of buildings*. Dublin: Dublin City Council (2004)

Changeworks. *Renewable Heritage - a guide to microgeneration in traditional and historic homes*. Edinburgh: Changeworks (2009) downloadable from www.changeworks.org.uk

Changeworks. *Energy Heritage - a guide to improving energy efficiency in traditional and historic homes*. Edinburgh: Changeworks (2008) downloadable from www.changeworks.org.uk

Cook, Martin Godfrey. *Energy Efficiency in Old Houses*. Wiltshire: Crowood Press (2009)

Department of the Environment, Heritage and Local Government. *Architectural Heritage Protection-Guidelines for Planning Authorities*. Dublin: The Stationery Office (2004)

Department of the Environment, Heritage and Local Government. *Technical Guidance Document L Conservation of Fuel and Energy - Dwellings*. Dublin: The Stationery Office (2008)

Department of the Environment, Heritage and Local Government. *Technical Guidance Document L Conservation of Fuel and Energy - Buildings other than Dwellings*. Dublin: The Stationery Office (2008)

Energy Savings Trust. *Energy Efficient Historic Homes - Case Studies*. London: Energy Savings Trust (2005)

English Heritage. *Energy Conservation in Traditional Buildings*. London: English Heritage (2008)

European Union. *Directive on the Energy Performance of Buildings*. (2002, recast 2010)

Historic Scotland. *Conversion of Traditional Buildings - Guide for Practitioners*. Edinburgh: Historic Scotland (2007)

National Standards Authority of Ireland. *The Installation of Solar Heating Systems*. Publication forthcoming (2010)

O'Cofaigh, E, Olley, J A and Lewis, J O. *The Climatic Dwelling: an introduction to climate-responsive residential architecture*. London: Earthscan Publications Ltd (1996)

Office of Public Works et al. *Green Design: sustainable building for Ireland*. Dublin: The Stationery Office (1996)

Sustainable Energy Ireland. *Energy in the Residential Sector*. Dublin (2008)

Wood, Chris, Bordass, Bill and Baker, Paul. *Research into the Thermal Performance of Traditional Windows: Timber Sash Windows*. London: English Heritage (2009)

Glossary

BIOMASS

Biodegradable fraction of products, waste and residues from agriculture (including vegetal and animal substances), forestry and related industries, as well as biodegradable fraction of industrial and municipal waste, used as a fuel or energy source

CAVITY WALL

A type of masonry construction comprising two leaves of masonry separated by a gap, or cavity, to prevent moisture from the outside transferring to the inside

DAMP-PROOF COURSE

An impervious layer built into a wall to prevent moisture penetrating the building

DELIVERED ENERGY

Energy supplied to a building and its systems to satisfy the relevant energy uses, for example space heating, water heating, cooling, ventilation or lighting. Delivered energy does not include renewable energy produced on site

EMBODIED ENERGY

The energy used in the manufacture, processing and transport of a material

MICRO-RENEWABLES

Technologies that produce heat and electricity at a small scale including solar panels, photovoltaic panels, domestic wind turbines, heat pumps and the like

PARGING

The application of lime mortar to the underside of roof slates or tiles

PHOTOVOLTAIC SYSTEMS

Arrays of solar cells containing a semi-conducting material that converts solar radiation into electricity

PUGGING

A material such as ash, sand or shells laid between floor joists or packed within partition walls to provide sound insulation

RENDER

A mixture of a binder (such as lime or cement), an aggregate and water to form a coarse plaster which is applied to the external surfaces of walls

RENEWABLE ENERGY

Energy from renewable non-fossil energy sources, for example solar energy (thermal and photovoltaic), wind, hydropower, biomass, geothermal, wave, tidal, landfill gas, sewage treatment plant gas and biogases

REPOINTING

The replacement of mortar in the face joints of brickwork or stonework following either the erosion of the original mortar or its removal through raking out

SOLAR GAIN

The heat absorbed by a building arising from its exposure to sunshine

THERMAL BRIDGING

This occurs when a portion of the construction of a building is colder than the surrounding construction, leading to condensation and possible mould formation on the cold surface. Also known as 'cold bridging'

THERMAL MASS

The ability of a building to absorb and store heat energy

THERMOGRAPHY

A type of photography that uses infra-red sensitive cameras to produce images which map the amount of heat emitted by an object

uPVC

Unplasticised Polyvinyl Chloride is a type of plastic vinyl used for making window frames, doors, rainwater pipes and some types of roof coverings

U-VALUE

A measure of the rate of heat transfer through a material expressed in W/m^2K : the faster the rate, the higher the U-value, therefore better insulators have a lower U-value

WHOLE-LIFE COSTING

The total cost of constructing and using a building over its life. The whole-life cost of a building includes the initial capital cost of building it (and all ancillary design and other costs) and the cost of operating and maintaining it over the period of its useful life

The Advice Series is a series of illustrated booklets published by the Architectural Heritage Advisory Unit of the Department of the Environment, Heritage and Local Government. The booklets are designed to guide those responsible for historic buildings on how best to repair and maintain their properties.

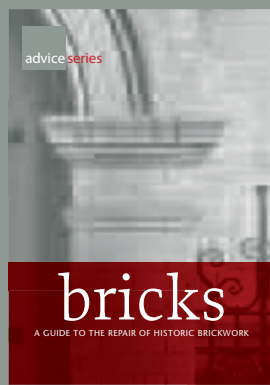
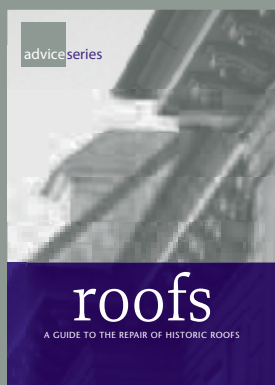

Traditionally built buildings perform differently from modern construction in the way they deal with damp and atmospheric moisture, and misguided works aimed at improving their thermal efficiency can have damaging consequences. This guide will help you to make the right decisions on how to increase the comfort and reduce the energy use of your historic building by giving advice on:

- ▶ Understanding how a traditionally built building works and how to maximise the levels of comfort for its occupants
- ▶ Choosing the most effective and cost-effective options for improving energy efficiency
- ▶ Avoiding damage to the building by inappropriate works
- ▶ Keeping a historic building in good health



Comhshaol, Oidhreacht agus Rialtas Áitiúil
Environment, Heritage and Local Government

© Government of Ireland 2010
Price €10

ISBN 978-1-4064-2444-7

